

- D** Anhängervorrichtung Montage- und Betriebsanleitung, Originalbetriebsanleitung
- CZ** Závěsné zařízení Montážní a provozní návod
- DK** Anhængertræk Montage- og driftsvejledning
- E** Enganche Instrucciones de montaje y de servicio
- F** Attelage Notice de montage et d'utilisation
- FIN** Perävaunun vetolaite Asennus- ja käyttöohjeet
- GB** Tow bar Installation and Operating Instructions
- GR** Διάταξη ζεύξης Οδηγίες συναρμολόγησης και λειτουργίας
- H** Vonóhorog Beszerelési utasítás
- I** Gancio di traino Istruzioni di montaggio e per l'uso
- N** Tilhengerfeste Monterings- og bruksanvisning
- NL** Trekhaak Montage- en gebruikshandleiding
- PL** Hak holowniczy Instrukcja montażu i eksploatacji
- RUS** Фаркоп Инструкция по монтажу и эксплуатации
- S** Dragkrok Monterings- och bruksanvisning

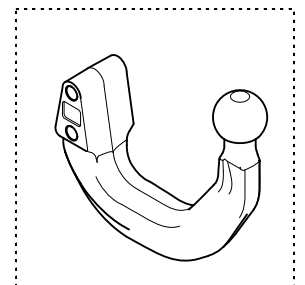
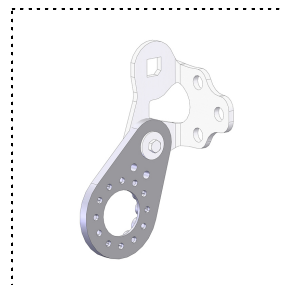
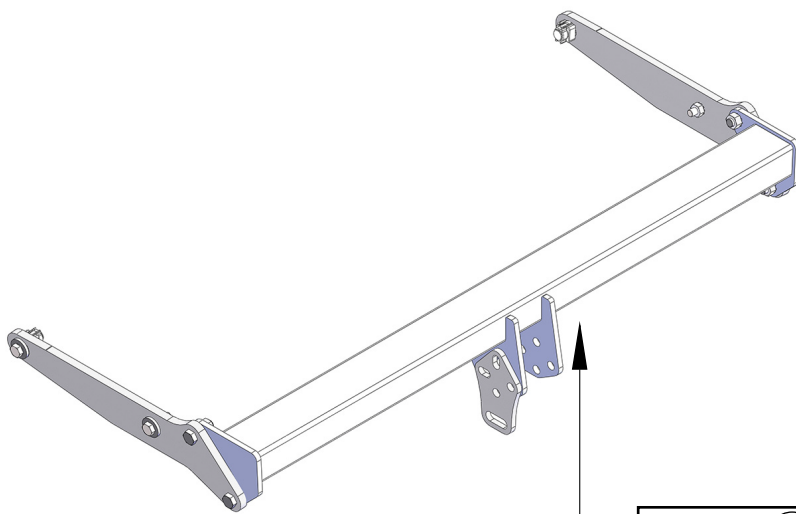

E11 55R-0111215  
**H**ORIZON  
GLOBAL

Part No: SK31U Alt Part No: 317133600002  
 A 50-X D = 12.3 kN S = 80 kg

  
 xxxxxxxxxxxxxxxxxxxxxxx

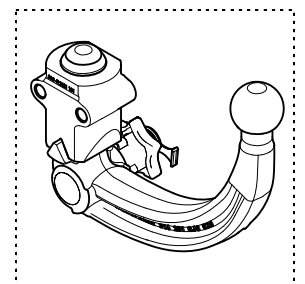

317 133 600 001  
 317 134 600 001

Skoda Kodiaq - 2016 →



4 x M10 x 40 x 1.5 (10.9)  
4 x M12 x 35 x 1.75 (8.8)

4 x M10 x 30mm

4 x M10

4 x M12

2 x M10

4 x M12

2 x M10

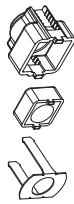

1 x

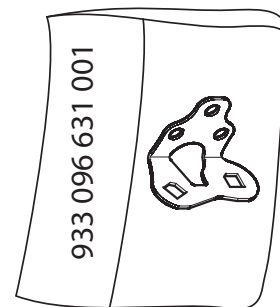
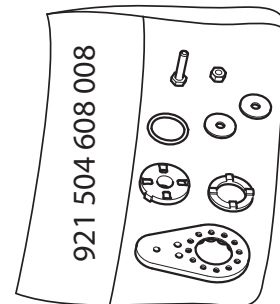
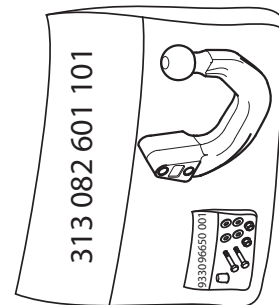
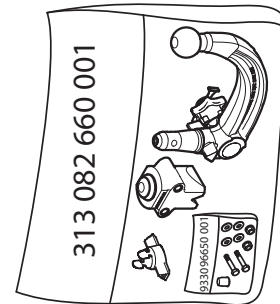
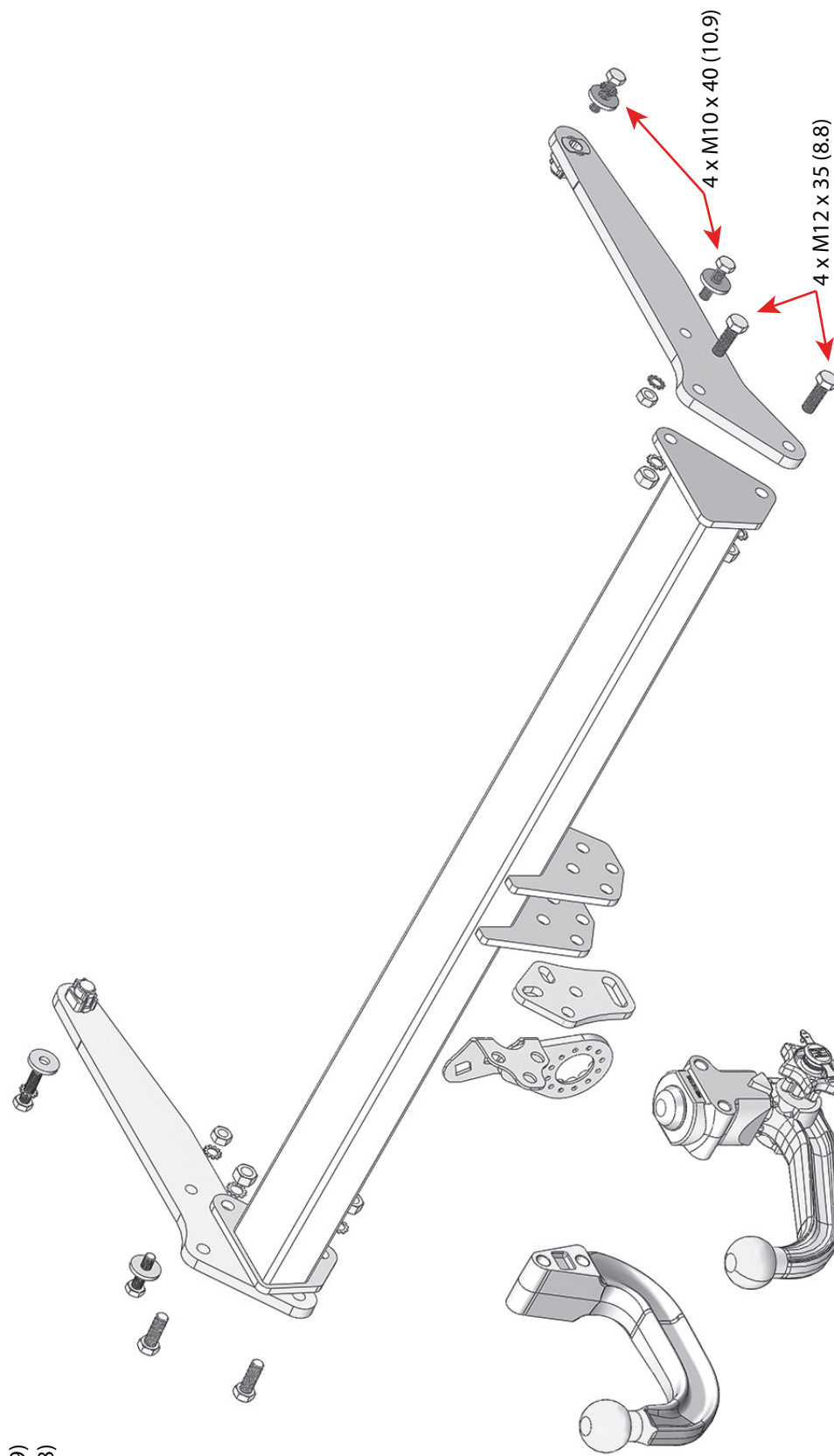
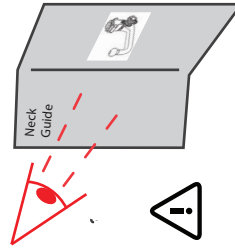
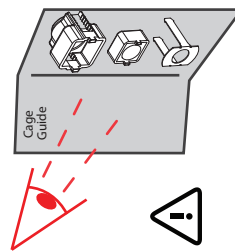

- D** Nationale Richtlinien über die Anbauabnahmen sind zu beachten.  
Jegliche Änderungen bzw. Umbauten an der Anhängervorrichtung sind verboten. Sie führen zum Erlöschen der Betriebserlaubnis. Die Anhängervorrichtung ist ein Sicherheitsteil und darf nur von Fachunternehmen montiert werden. Bei falscher Montage besteht schwere Unfallgefahr! Der deutsche Text dieser Anleitung ist bindend. Änderungen vorbehalten.
- CZ** Je nutné dodržovat místní směrnice o demontáži nástaveb.  
Veškeré změny příp. přestavby tažného zařízení jsou zakázány. Mají za následek zánik platnosti povolení k provozu. Tažné zařízení je bezpečnostní součástí, kterou smí montovat pouze odborné podniky. Při chybné montáži hrozí vážné nebezpečí nehody! Německý text tohoto návodu je závazný. Změny vyhrazeny.
- DK** De nationale direktiver for afmontering af påmonterede dele skal overholdes.  
Enhver ændring eller ombygning på anhængertrækket er forbudt. Dette medfører, at typegodkendelsen udløber. Anhængertrækket er en sikkerhedsdel og må kun monteres af autoriserede firmaer. Ved forkert montering er der fare for alvorlige ulykker! Den tyske tekst i denne vejledning er bindende. Ret til ændringer forbeholdes.
- E** Deben respetarse las directivas nacionales referentes a controles de enganches.  
Está prohibido modificar o remodelar el dispositivo de remolque. La consecuencia sería la invalidación del permiso de circulación. ¡En caso de montaje erróneo existe peligro de accidentes graves! Es vinculante el texto alemán de estas instrucciones. Nos reservamos el derecho a efectuar modificaciones.
- F** Les dispositions nationales concernant la réception à titre isolé doivent être respectées.  
Toute modification ou transformation du dispositif d'attelage est interdite. Elle entraînerait l'annulation de la réception. Le dispositif d'attelage est un équipement de sécurité et doit être mis en place exclusivement par un atelier spécialisé. Un montage incorrect représente un risque élevé d'accident ! Le texte allemand de cette notice fait foi. Sous réserve de modifications.
- FIN** Kansallisia asennusten teknistä hyväksymistä koskevia määräyksiä on noudatettava.  
Kaikki vetolaitteeseen tehtävät muutokset tai jälkiasennukset ovat kiellettyjä. Nämä johtavat käyttöluvan raukeamiseen. Vetolaite on turvallisuuheen vaikuttava osa, jonka saa asentaa vain alan erikoisliike. Virheellinen asennus voi aiheuttaa vakavan onnettomuuden! Tämän ohjeen saksankielinen teksti on sitova. Oikeudet muutoksiin pidätetään.
- GB** National guidelines concerning official approval of auxiliaries must be observed.  
Any alteration or modification of the towing hitch is prohibited and voids the operating licence. Remove the insulating compound and underbody coating - if there is any - from the area around the contact surface of the trailer hitch. A trailer hitch is a safety-critical part and may be fitted only by qualified companies. Improper assembly may result in a serious accident hazard! The German text of this instruction is binding. Subject to change.
- GR** Πρέπει να τηρούνται οι κρατικοί κανονισμοί σχετικά με τον έλεγχο προσθηκών στα αμαξώματα .  
Απαγορεύονται οι αλλαγές και οι μετατροπές στην διάταξη ρυμούλκησης . Συναπάγονται την ακύρωση της άδειας λειτουργίας . Ο κοτσαδόρος είναι ένα εξάρτημα ασφαλείας και η τοποθέτηση του επιτρέπεται να γίνεται μόνο από εξειδικευμένο συνεργείο . Σε περίπτωση λάθους τοποθέτησης υπάρχει κίνδυνος σοβαρών ατυχημάτων ! Το γερμανικό κείμενο αυτών των οδηγιών είναι δεσμευτικό . Διατηρούμε το δικαίωμα αλλαγών .
- H** Figyelembe kell venni a műszaki átvételre vonatkozó nemzeti irányelveket.  
A vonószerkezeten tilos bármiféle átalakítást végezni. A szerkezet megváltoztatása vagy átalakítása a forgalmi engedély megszüntését vonja maga után. A vonószerkezet egy biztonsági felszerelés, amelyet csak szaküzem szerelhet fel. Helytelen szerelés súlyos balesethez vezethet! A német szerelési utasítás betartása kötelező. Változtatások jogát fenntartjuk.
- I** Devono essere osservate le normative nazionali sui collaudi.  
È vietato modificare o montare diversamente il gancio di traino. Ciò comporta l'annullamento del permesso di circolazione. Il gancio di traino è un componente di sicurezza e deve essere montato esclusivamente da personale specializzato. In caso di montaggio errato sussiste il pericolo di incidenti gravi! È vincolante il testo tedesco di queste istruzioni. Con riserva di modifiche.
- N** Nasjonale retningslinjer om godkjennelse av monteringer skal overholdes.  
Enhver endring hhv. ombygging av tilhengerfestet er forbudt. Dette vil ødelegge brukeropplevelsen. Tilhengerfestet er en sikkerhetskomponent og skal monteres av fagbedrift. Det er stor fare for at det kan oppstå ulykker ved feil montering! Den tyske teksten i denne veiledningen er bindende. Med forbehold om endringer.
- NL** Nationale richtlijnen betreffende de montagegoedkeuring moeten in acht worden genomen.  
Elke wijziging van de aanhanger is verboden. Wijziging leidt tot verval van de gebruikstoestemming. De aanhanger is veiligheidsonderdeel en mag alleen door vakkundig personeel worden gemonteerd. Bij verkeerde montage bestaat ernstig gevaar voor ongevallen! De Duitse tekst van deze handleiding is bindend. Wijzigingen voorbehouden.

PL

Proszę przestrzegać krajowych wytycznych dotyczących odbioru technicznego.

Wszelkie zmiany lub przebudowy haka holowniczego są zabronione. Spowodują one utratę ważności świadectwa homologacji.

Hak holowniczy stanowi element bezpieczeństwa i może zostać zamontowany wyłącznie przez firmę specjalistyczną. W przypadku nieprawidłowego montażu istnieje poważne ryzyko wypadku! Tekst niniejszej instrukcji w języku niemieckim jest wiążący. Zmiany zastrzeżone.

RUS

Подлежат соблюдению национальные директивы о порядке приемки навесного /встраиваемого оборудования .

Какие-либо изменения и переделки фаркопа недопустимы. Они делают недействительным разрешение на эксплуатацию.

Сцепное устройство - это узел, несущий предохранительные функции, и к его монтажу допускаются только специалисты.

При неправильном монтаже грозит опасность тяжелых травм! Обязательным является немецкий текст данной

инструкции.

Право на внесение изменений сохраняется.

S

Nationella riktlinjer betröffande monteringen skall beaktas.

All form av ändring respektive ombyggnad på dragkroken är förbjuden. Förändringar resulterar i att typgodkännandet upphör att gälla.

Dragkroken är en säkerhetskomponent och bör endast monteras av kvalificerade tekniker. Vid felaktig montering föreligger risk för allvarliga olyckor! Den tyska texten i denna anvisning är bindande. Ändringar förbehålls.

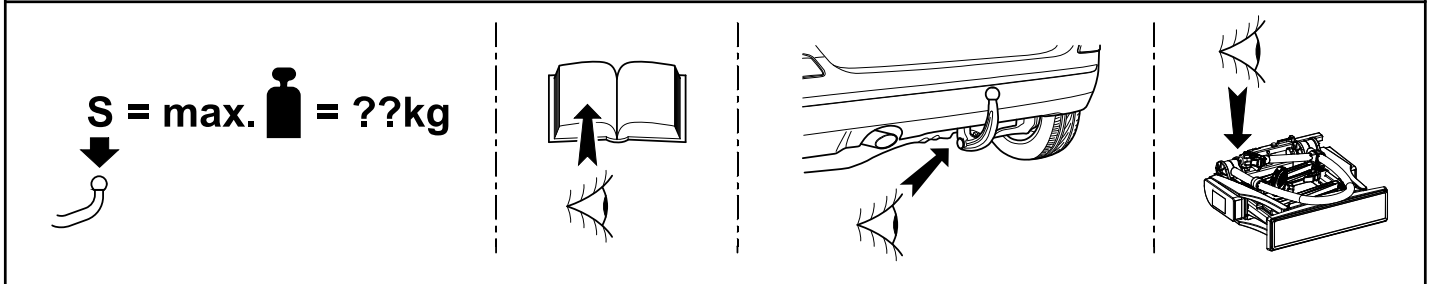
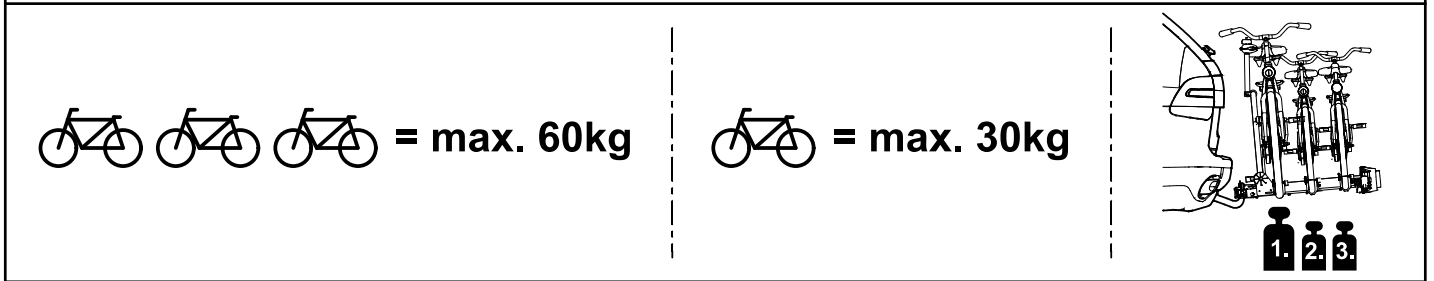
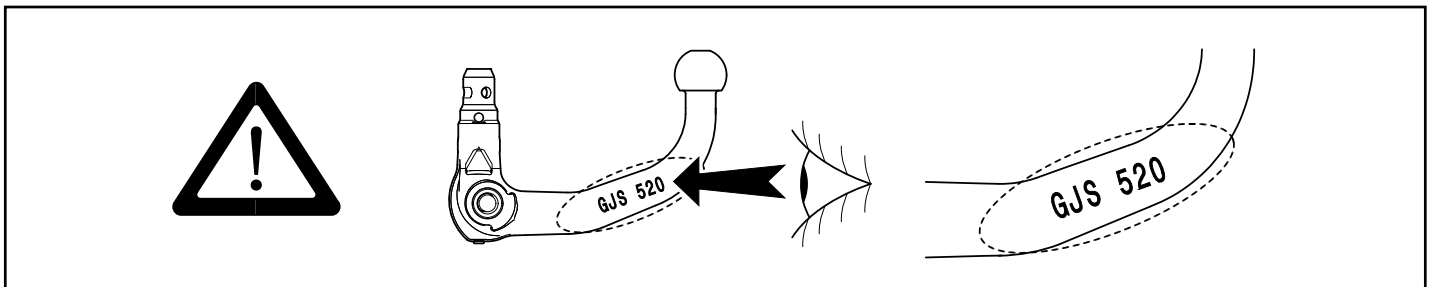
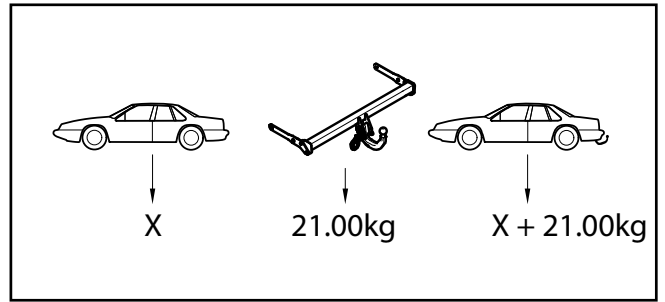
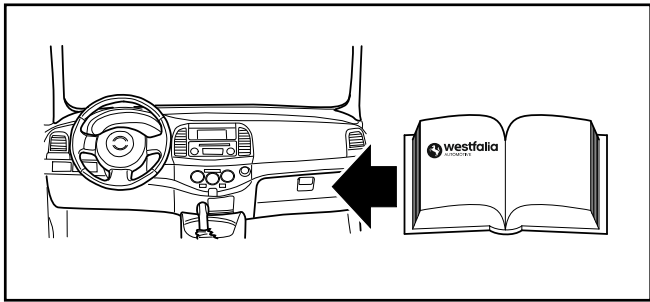
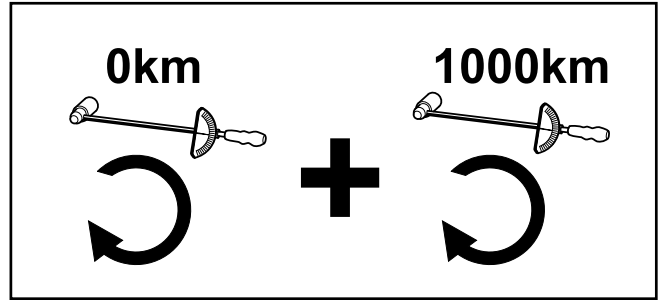
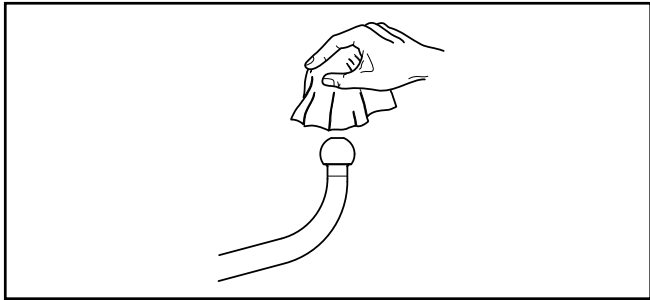
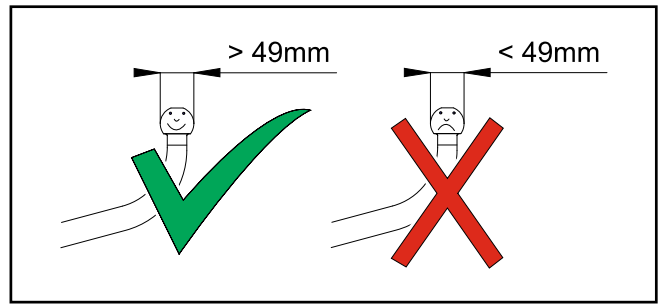
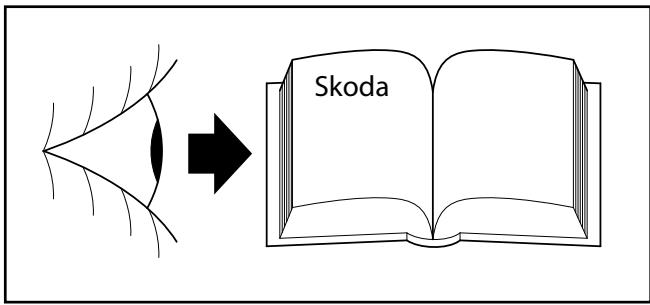

1.

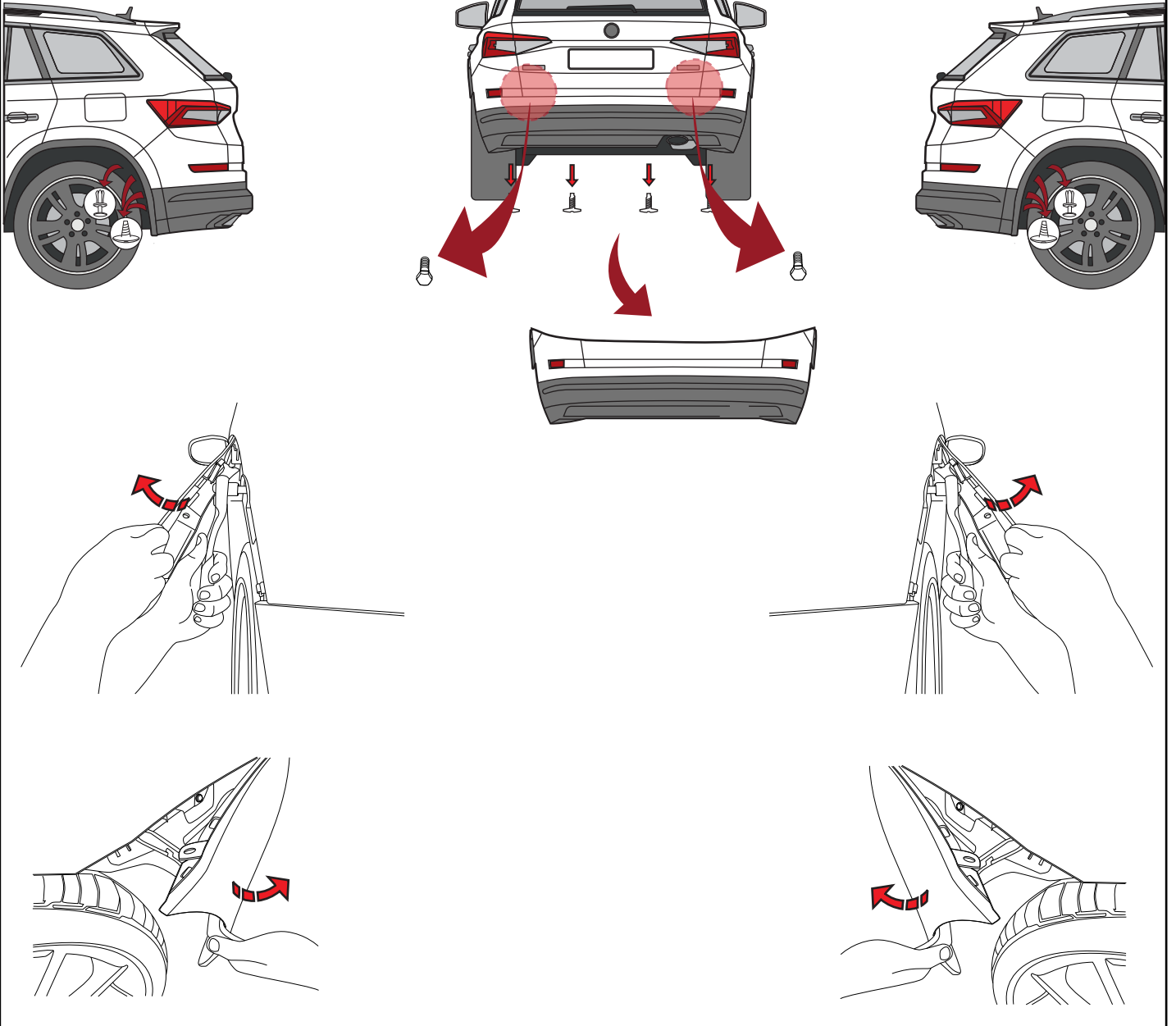

2.

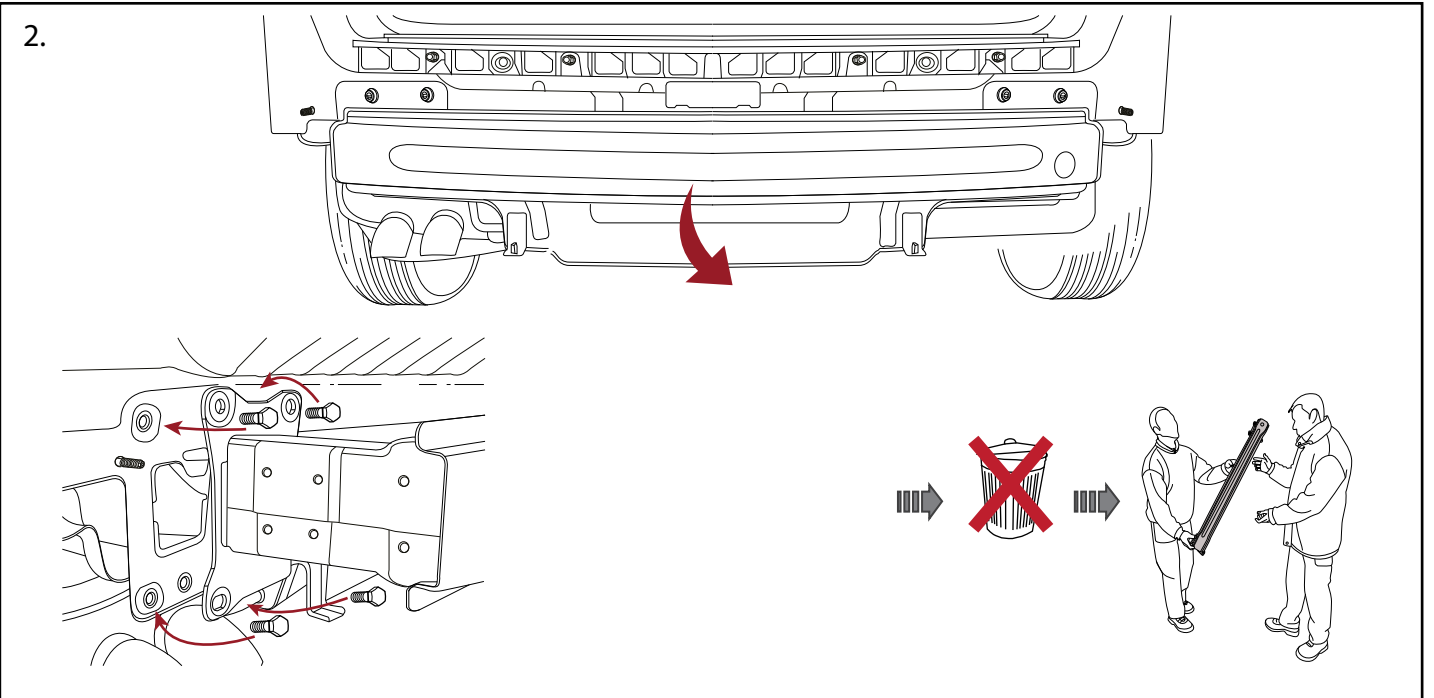

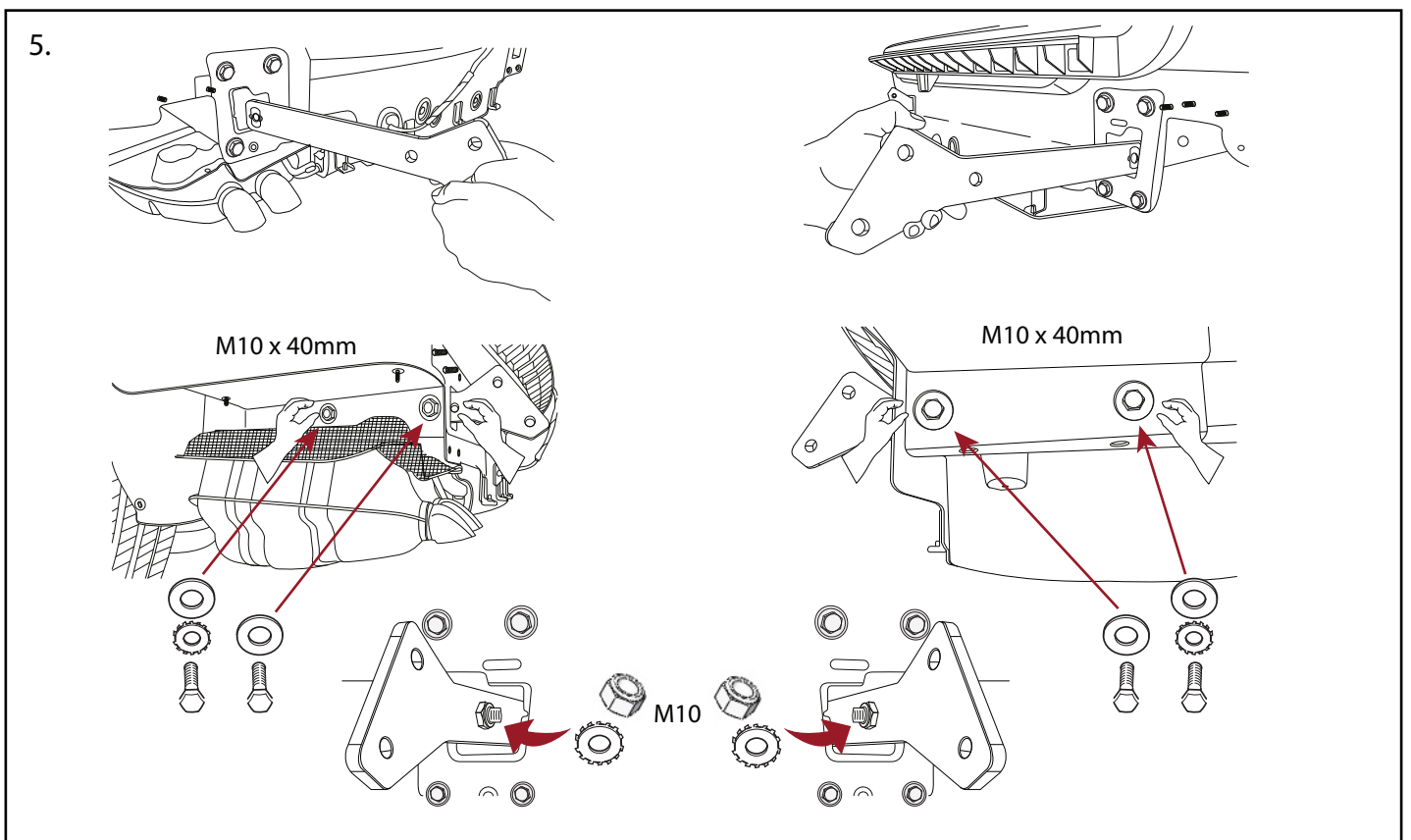
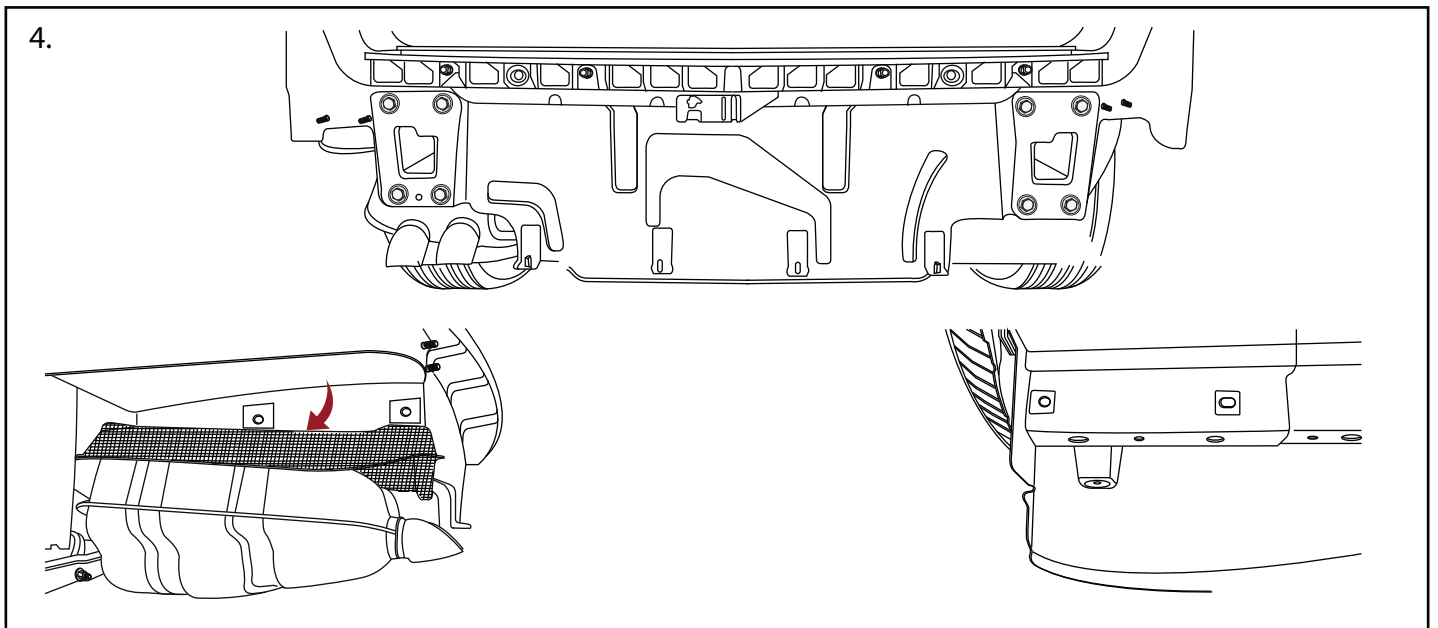
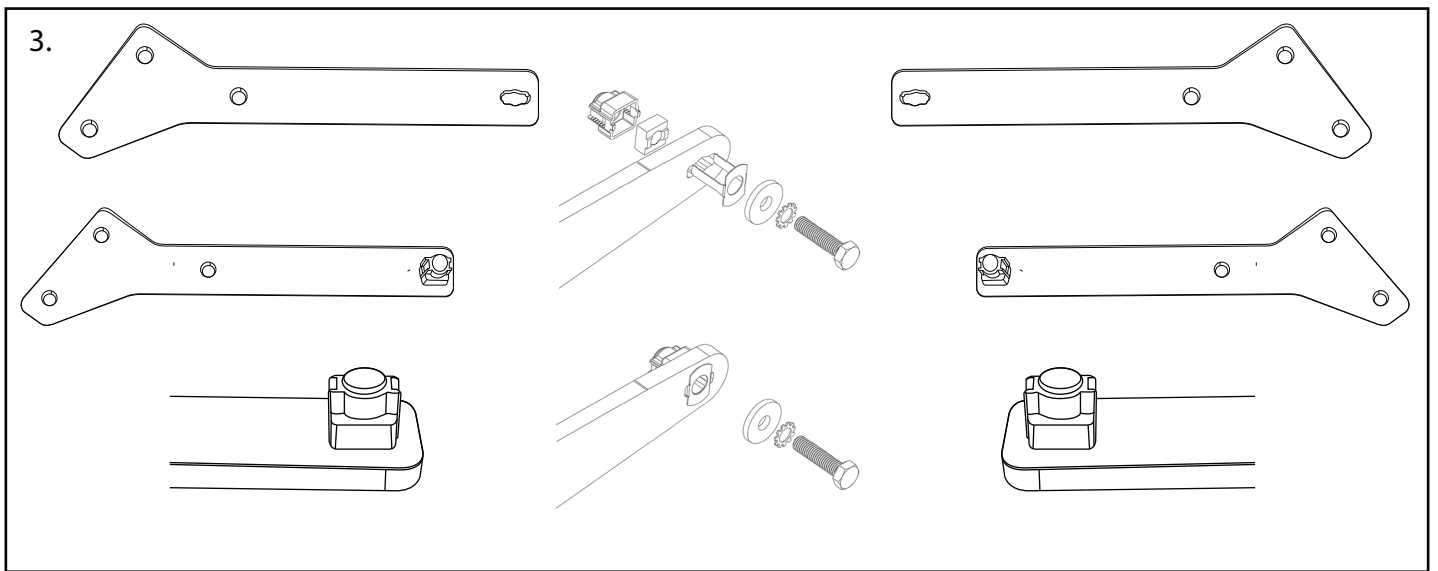

6.

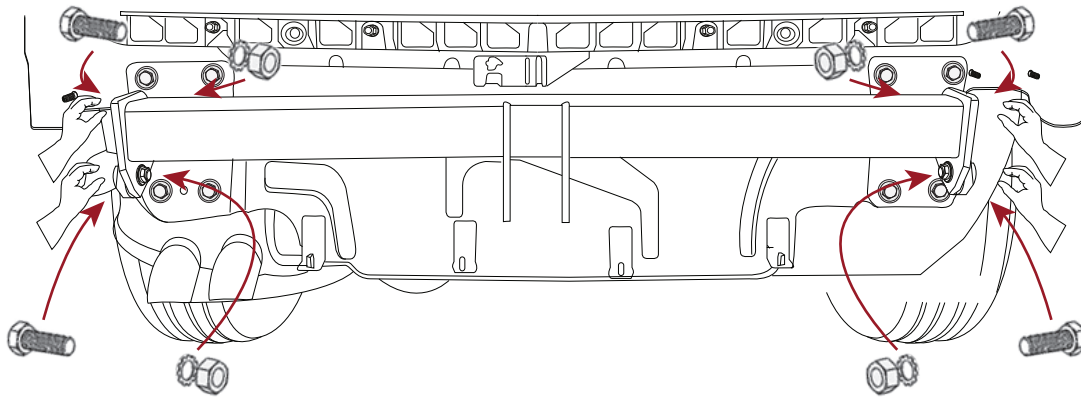

M12 x 35mm

M12 x 35mm

7.

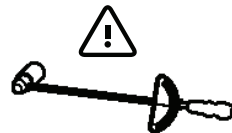
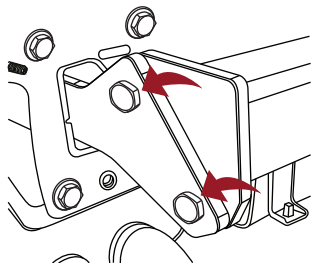
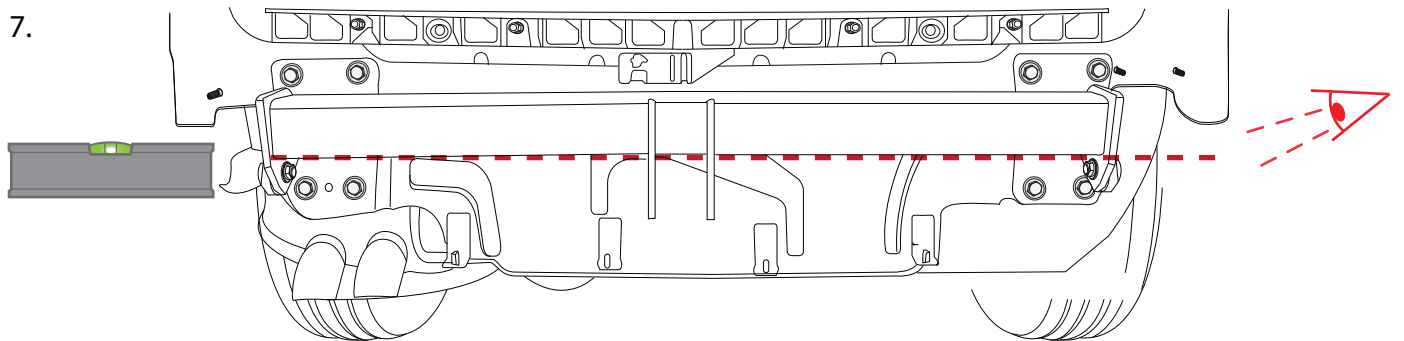

M12 - 80 Nm  
8.8

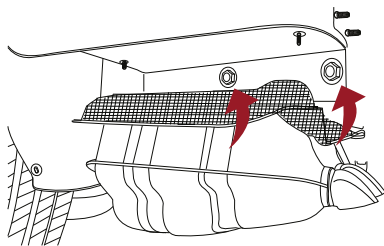
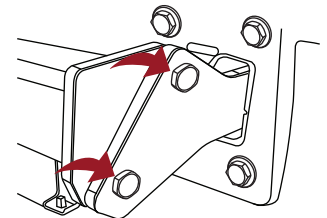

M10 - 70 Nm  
10.9

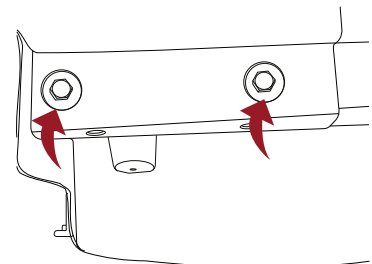

8.



+ page 9.

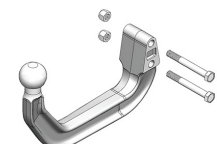
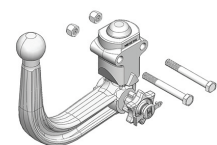
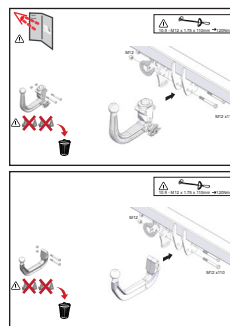



9.

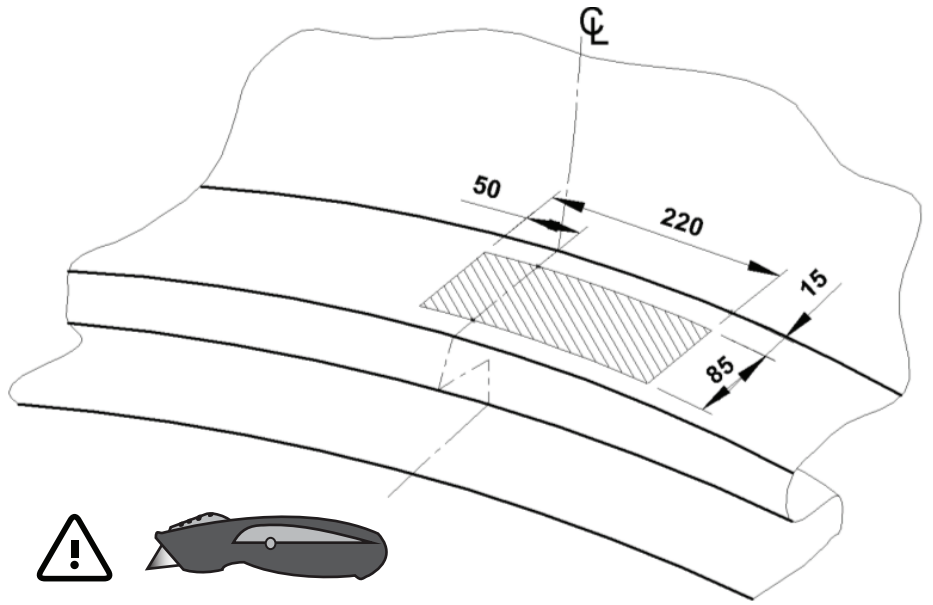
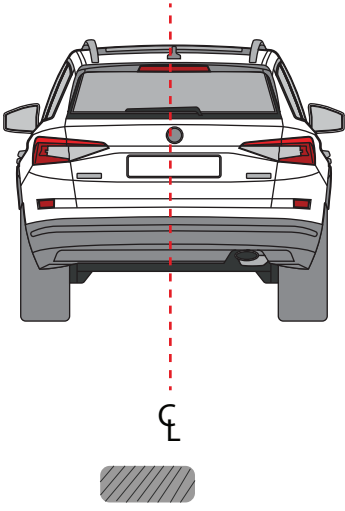

10.

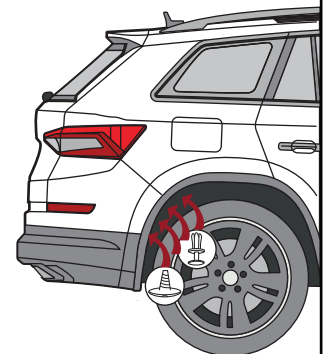
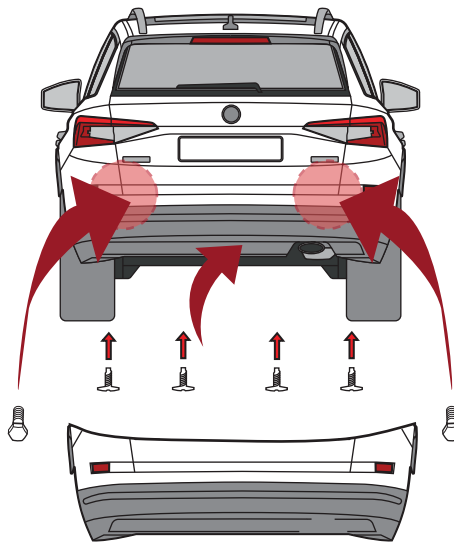
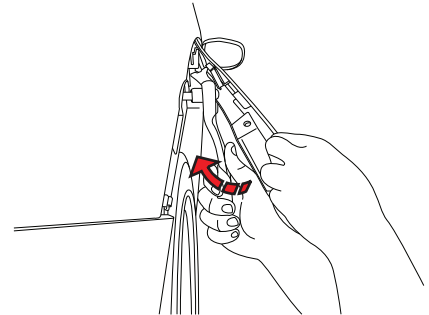
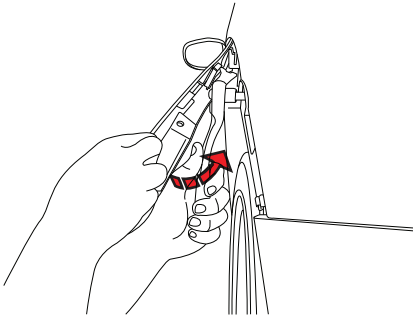
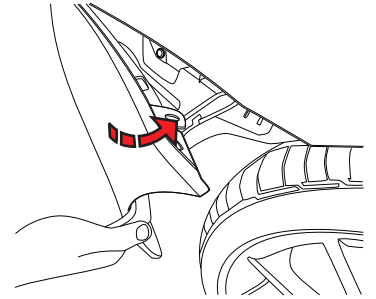
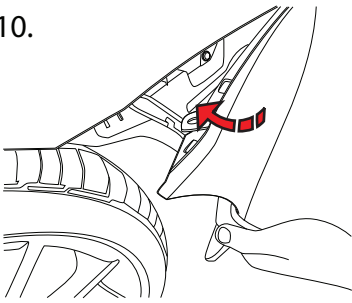

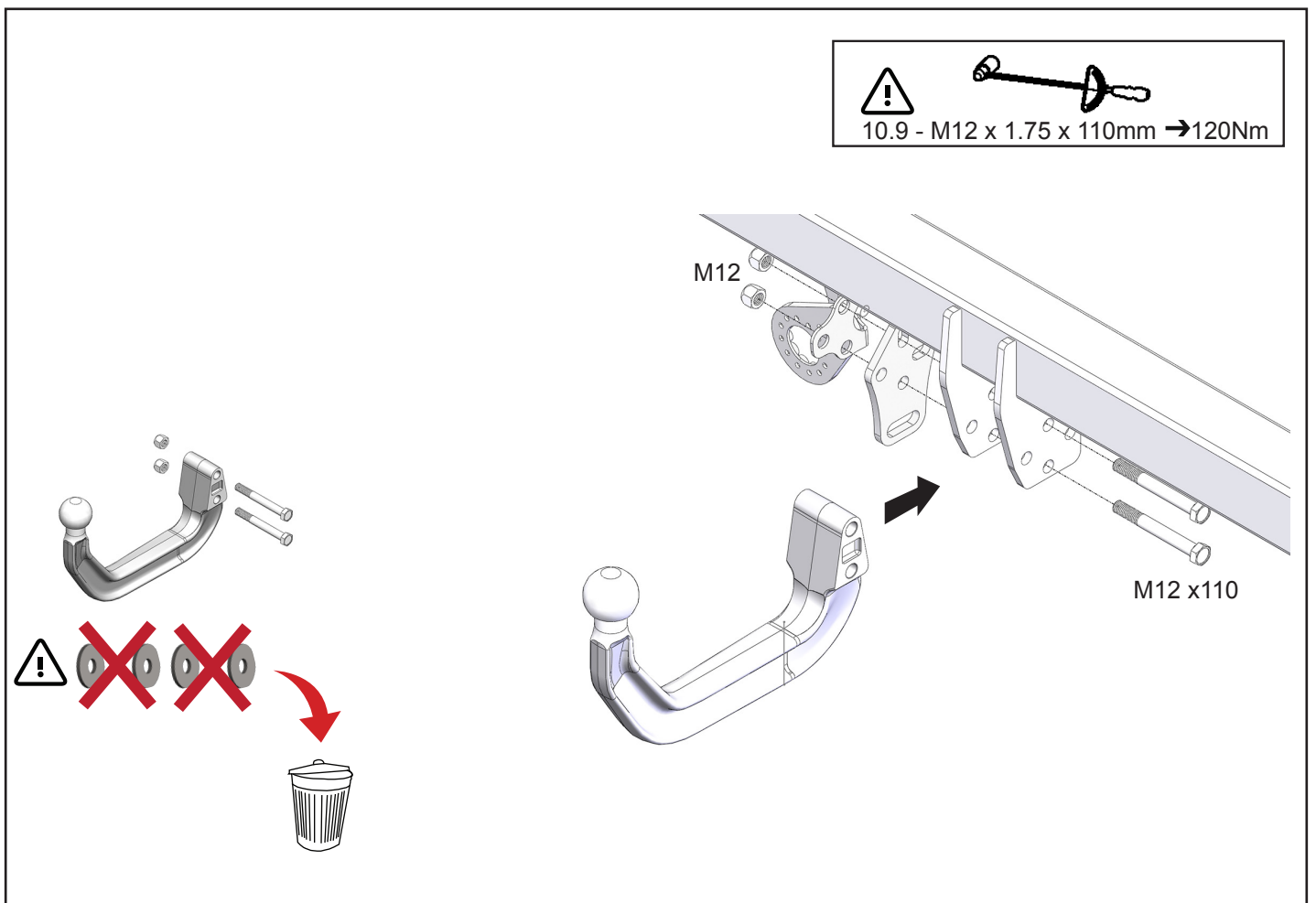
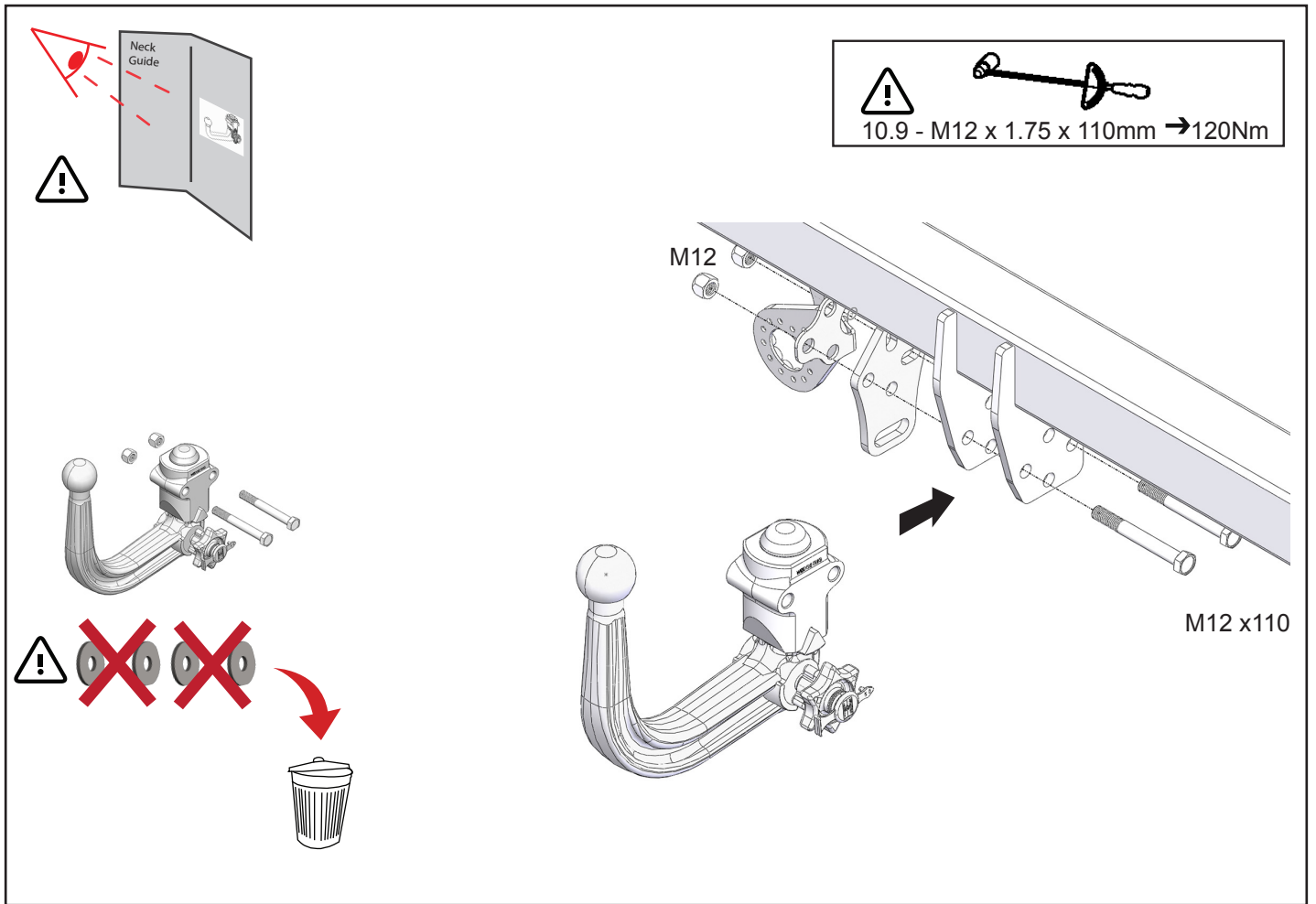

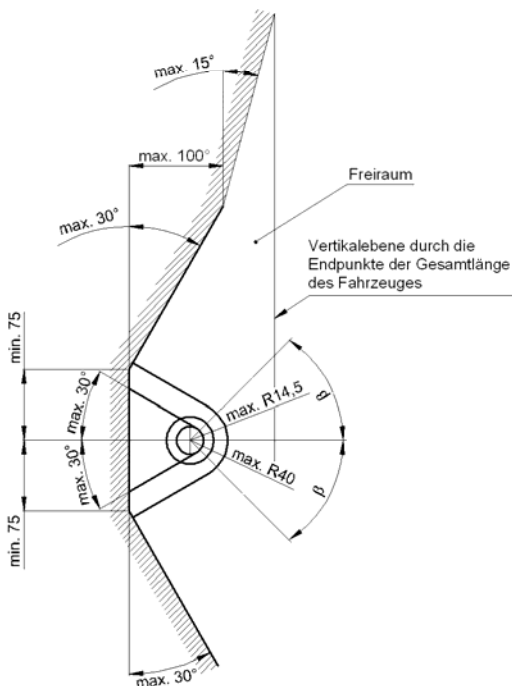
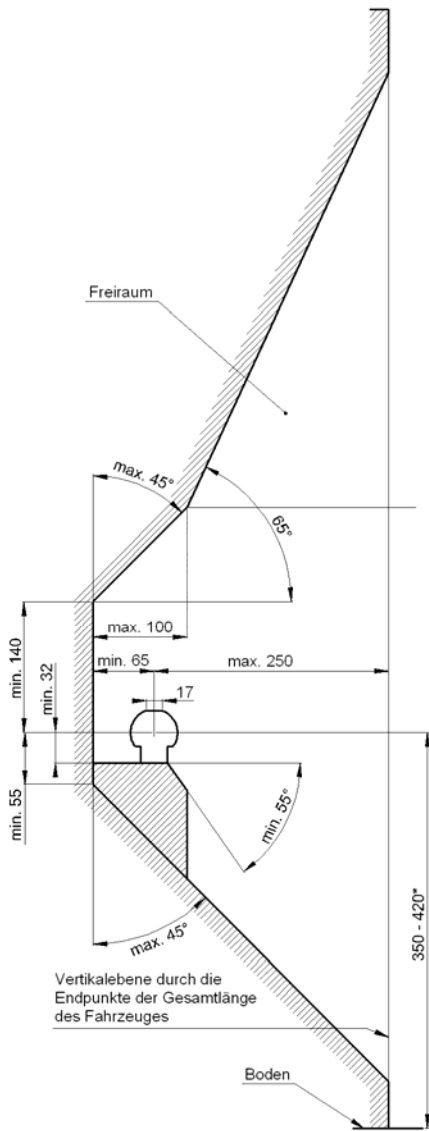

- D** Der Freiraum nach Anhang 7, Abbildung 25a und 25b der Richtlinie ECE-R 55 ist zu gewährleisten.
- CZ** Volný prostor ve smyslu Přílohy 7, obr. 25a a 25b směrnice ECE-R 55 musí být zaručen.
- DK** Det skal sikres, at der er spillerum i overensstemmelse med bilag 7, fig. 25a og 25b i henhold til direktiv ECE-R 55.
- E** Hay que garantizar el espacio libre conforme al anexo 7, fig. 25a y 25b de la directiva ECE-R 55.
- F** La zone de dégagement, selon l'annexe 7, figure 25a et 25b de la directive ECE-R 55, doit être assurée.
- FIN** Vällyksen tulee täyttää ohjeen ECE-R 55 liitteen 7 kuvissa 25a ja 25b ilmoitetut vaatimukset.
- GB** Make sure to provide clearance according to appendix 7, figures 25a and 25b of the ECE-R 55 regulations.
- GR** Πρέπει να εξασφαλίζεται ο ελεύθερος χώρος σύμφωνα με το παράρτημα 7, σχήμα 25a και 25b της κοινοτικής οδηγίας ECE-R 55.
- H** Biztosítani kell az ECE-R 55 irányelv szerinti, 7. számú függelék, 25a. és 25b ábrákban jelölt szabad teret.
- I** Deve essere garantito lo spazio libero secondo l'allegato 7, figure 25a e 25b della normativa europea ECE-R 55.
- N** Det må sørges for fritt rom i samsvar med tillegg 7, figur 25a og 25b i direktiv ECE-R 55.
- NL** De vrije ruimte volgens supplement 7, afbeelding 25a en 25b van richtlijn ECE-R 55 moet gewaarborgd zijn.
- PL** Należy zapewnić wolną przestrzeń zgodnie z załącznikiem 7, rys. 25a i 25b, dyrektywy ECE-R 55.
- RUS** Оставлять свободное пространство согласно Приложению 7, рис. 25a и 25b Директивы ECE-R 55.
- S** Spelrummet enligt bilaga 7, bild 25a och 25b i riktlinje ECE-R 55, måste garanteras.

- D** \* bei zulässigem Gesamtgewicht des Fahrzeuges
- CZ** \* při celkové přípustné hmotnosti vozidla
- DK** \* ved tilladt totalvægt for køretøjet
- E** \* con peso total autorizado del vehículo
- F** \* pour poids total en charge autorisé du véhicule
- FIN** \* Ajoneuvon suurimmalla sallitulla kokonaispainolla
- GB** \* at gross vehicle weight rating
- GR** \* για το επιτρεπτό μικτό βάρος του οχήματος
- H** \* A jármű megengedett összsúlyja esetén
- I** \* per il peso complessivo ammesso del veicolo
- N** \* ved kjøretøyets tillatte totalvekt
- NL** \* bij toegestaan totaal gewicht van het voertuig
- PL** \* przy dopuszczalnym ciężarze całkowitym pojazdu
- RUS** \* при допустимом общем весе автомобиля
- S** \* vid fordonets tillåtna totalvikt

Dispositivo di traino tipo: SK31U  
Per autoveicolo: Skoda Kodiaq 2016 →  
Tipo funzionale: NS

Classe e tipo di attacco: A50-X  
Omologazione: E11 55R-0111215  
Valore D: 12.3kN  
Carico verticale max. S: 80 kg  
Massa rimorchiabile: vedi carta di circolazione dell'autoveicolo

In base alla Direttiva europea ECE-R 55, la massa massima rimorchiabile del dispositivo di traino è determinata dal valore di prova "D" così definito:

$$D = (T \times C) / (T + C) \times 0,00981 = \dots \text{ kN}$$

dove: T = Massa complessiva max. della motrice (in kg) e C = Massa rimorchiabile max. della motrice (in kg)

**DICHIARAZIONE DI CORRETTO MONTAGGIO:**

la sottoscritta Ditta dichiara che il dispositivo di traino tipo.....è stato installato a regola d'arte, nel rispetto dei punti d'attacco e delle prescrizioni fornite dalla Casa costruttrice

.....sul veicolo.....

.....targato .....

.....Il.....

timbro e firma

.....

Si dichiara inoltre di aver informato l'utente del veicolo sull'USO e MANUTENZIONE del dispositivo stesso.

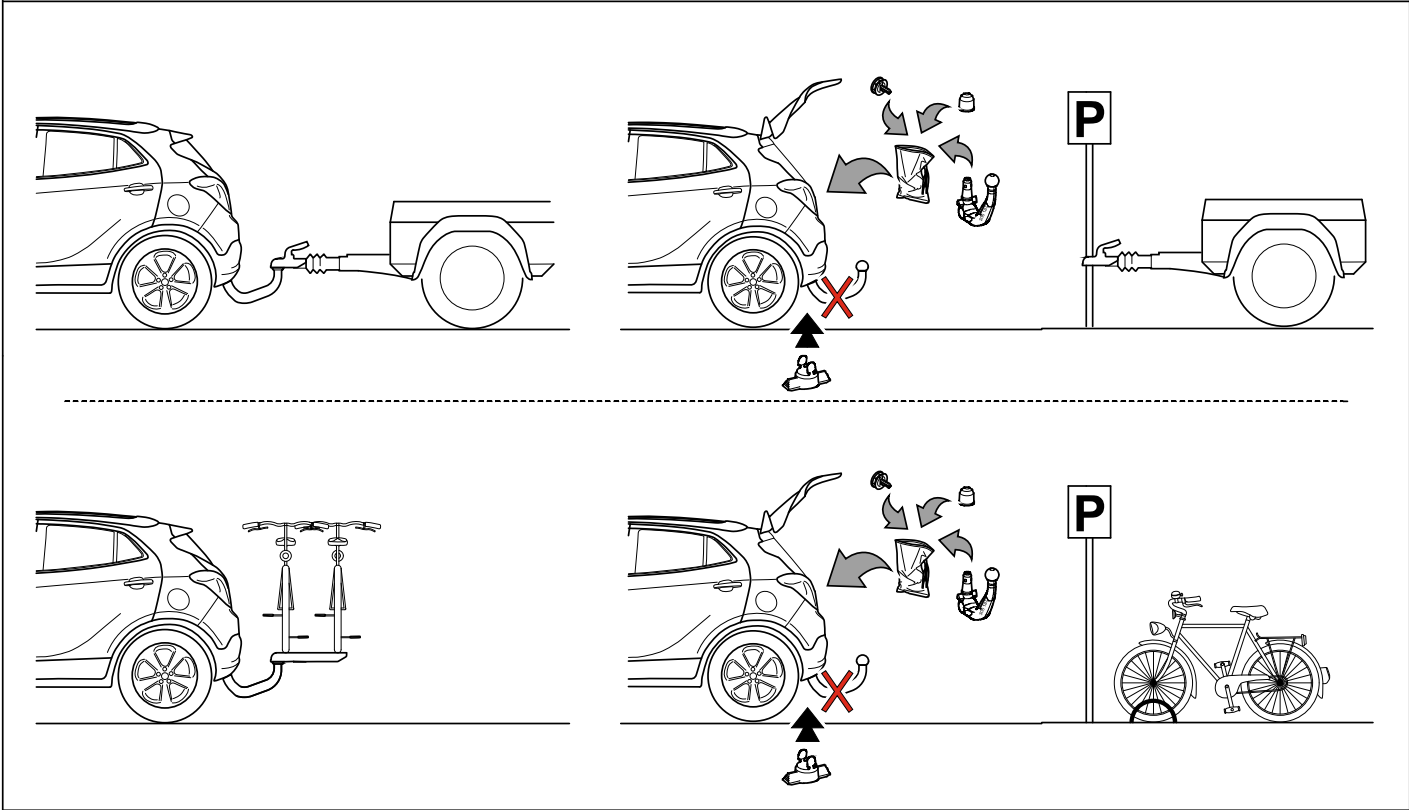
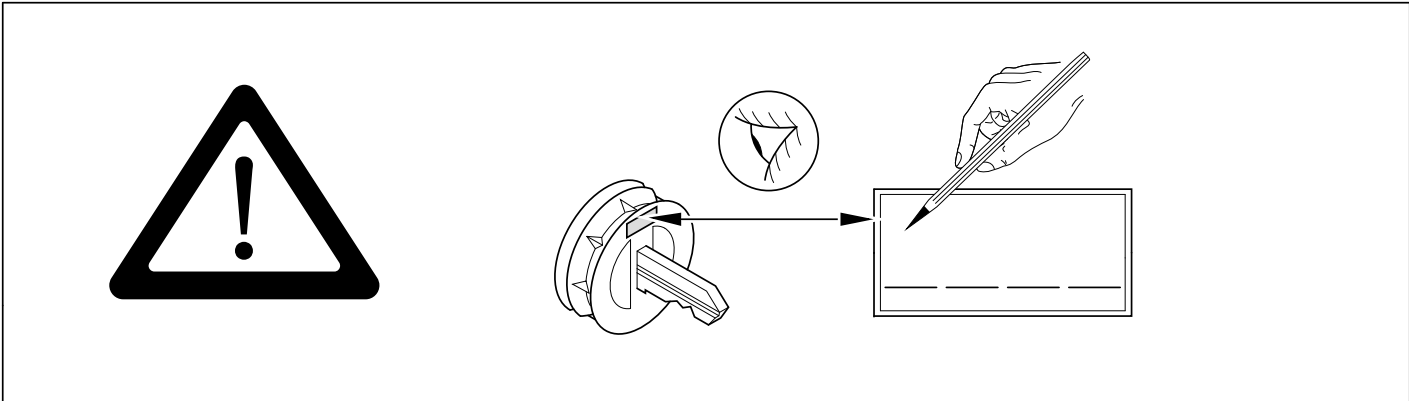
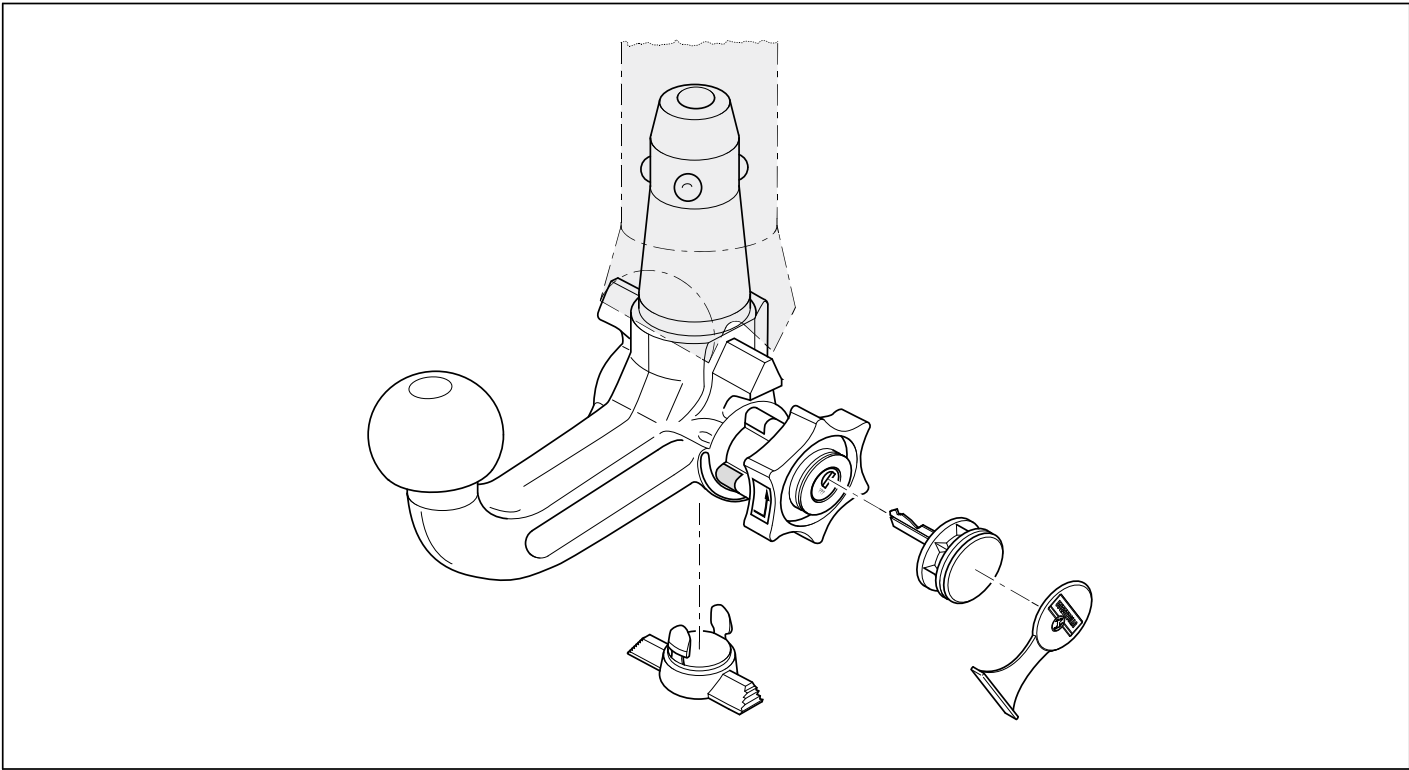

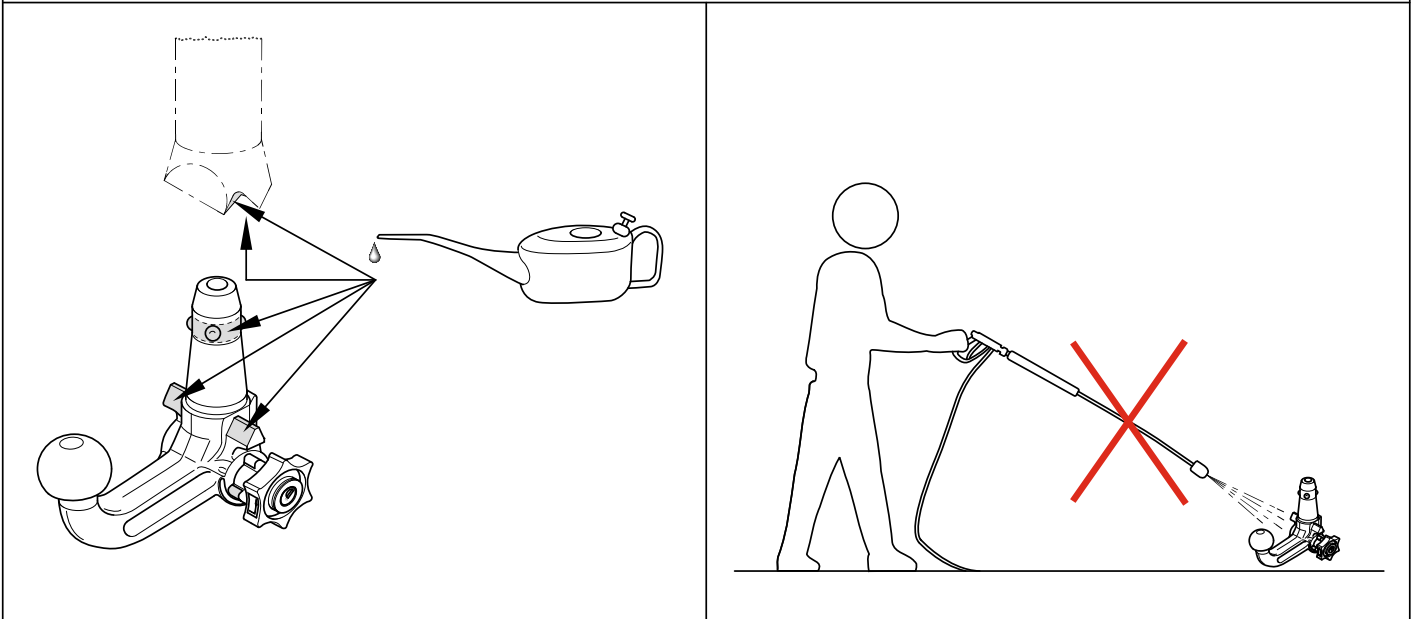
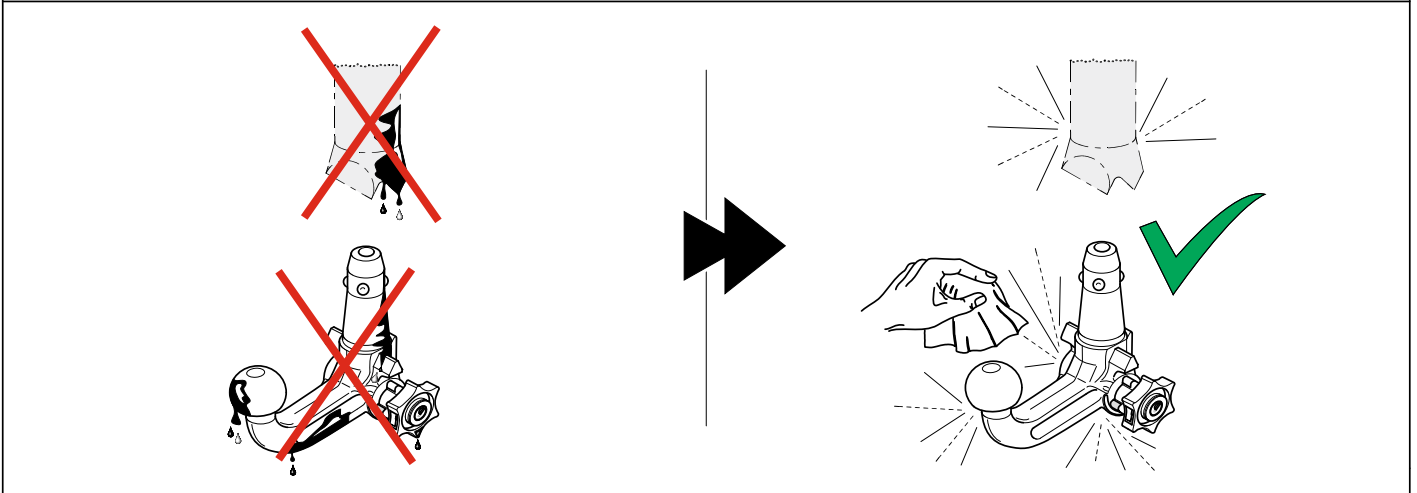
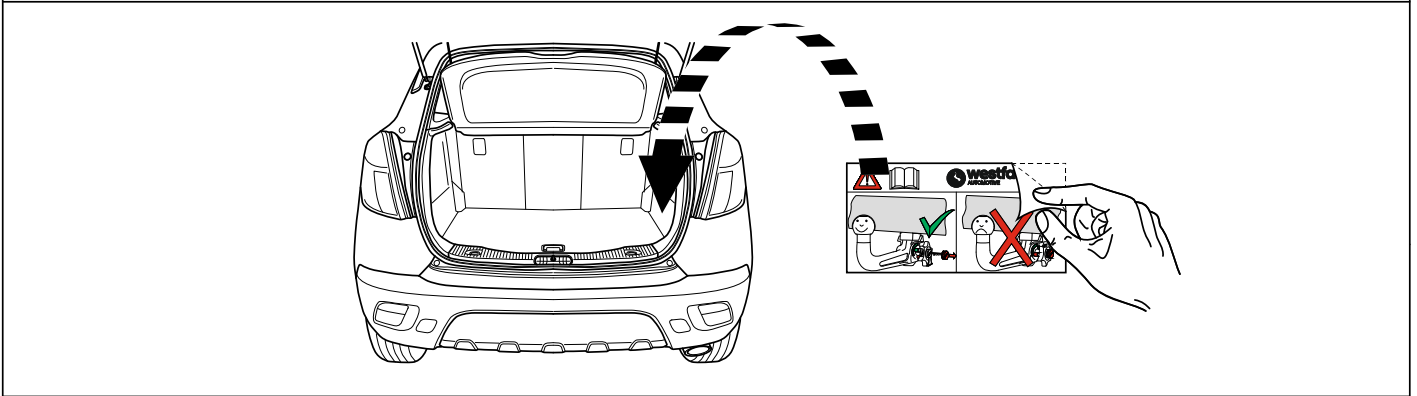
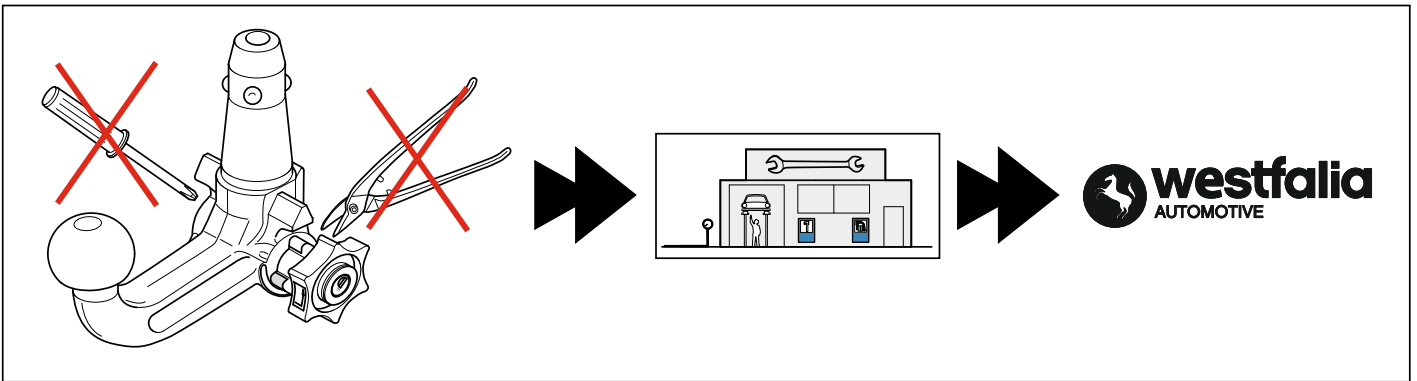

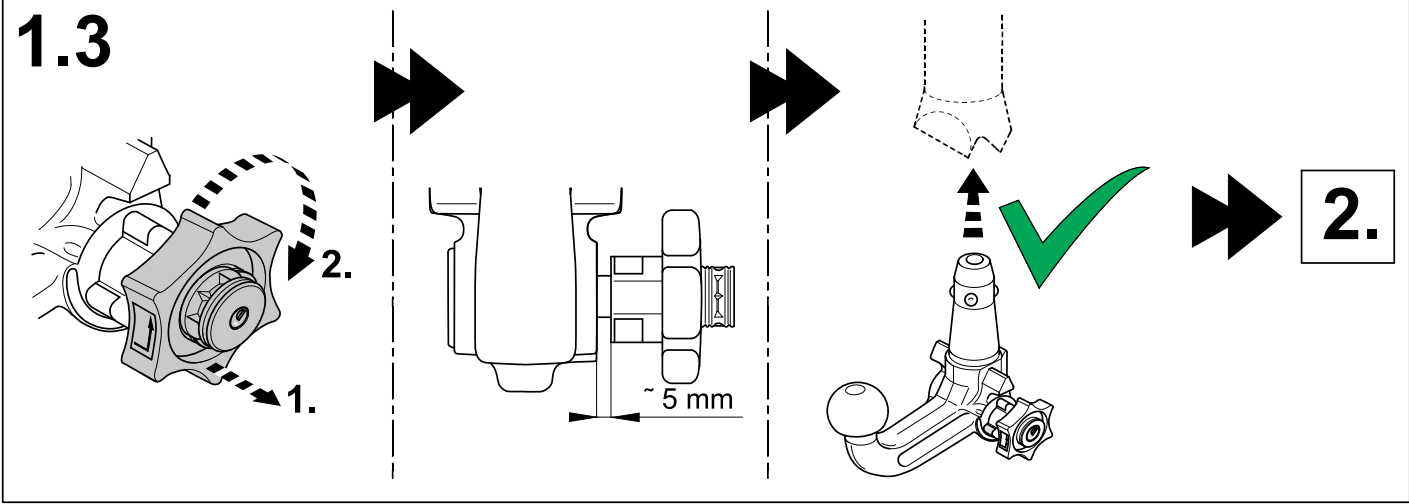
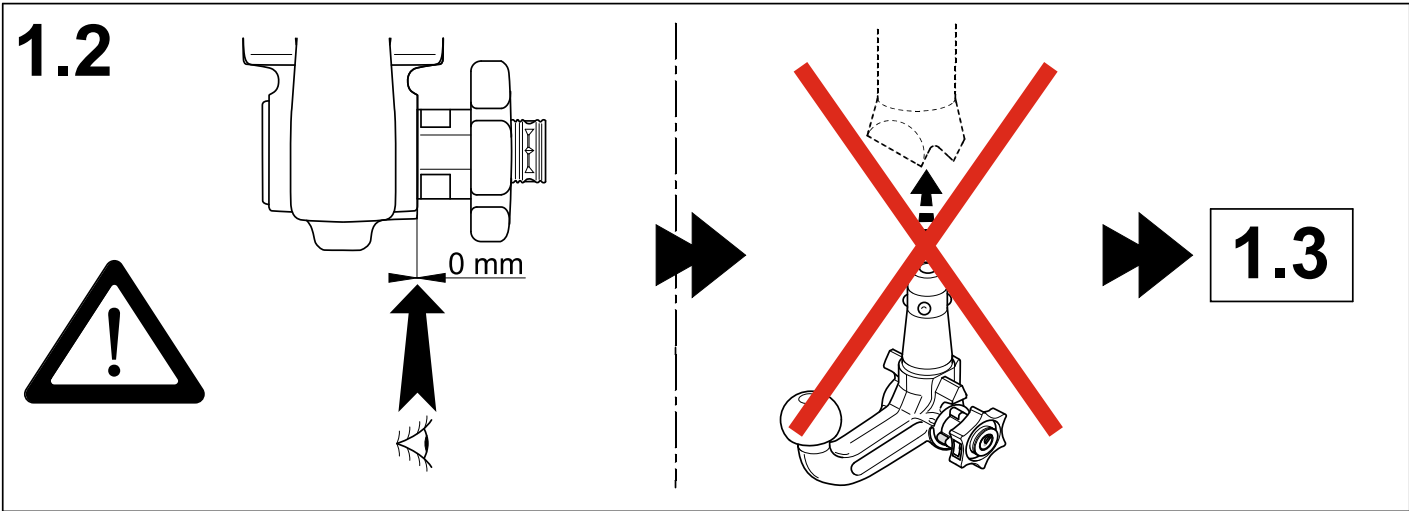
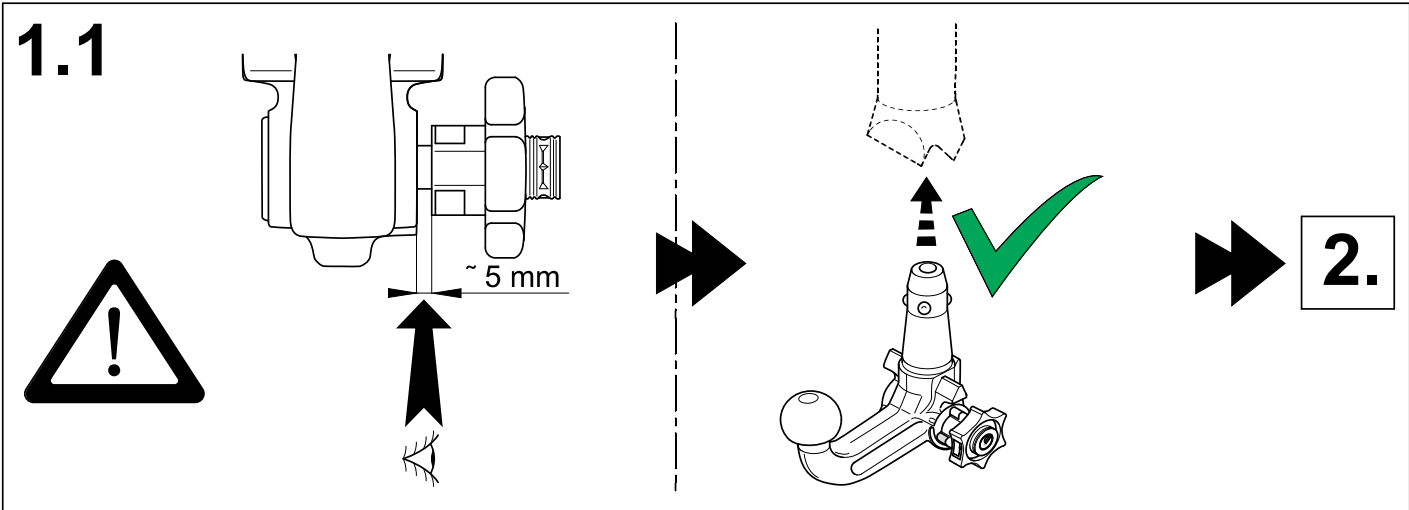
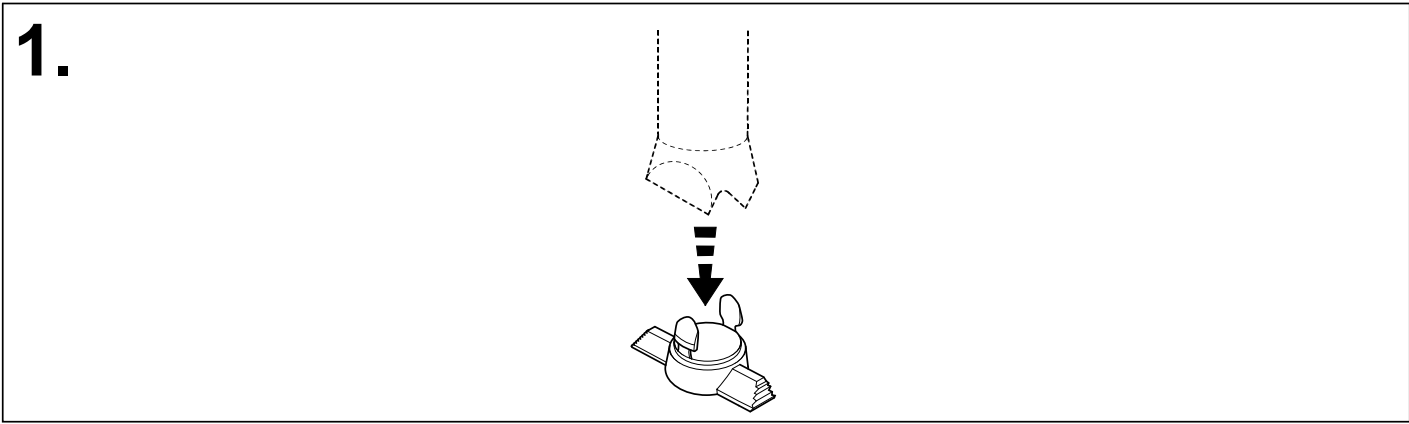

2.

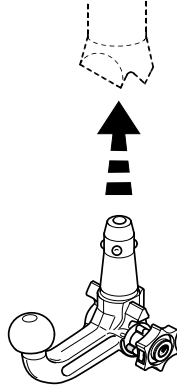

2.1

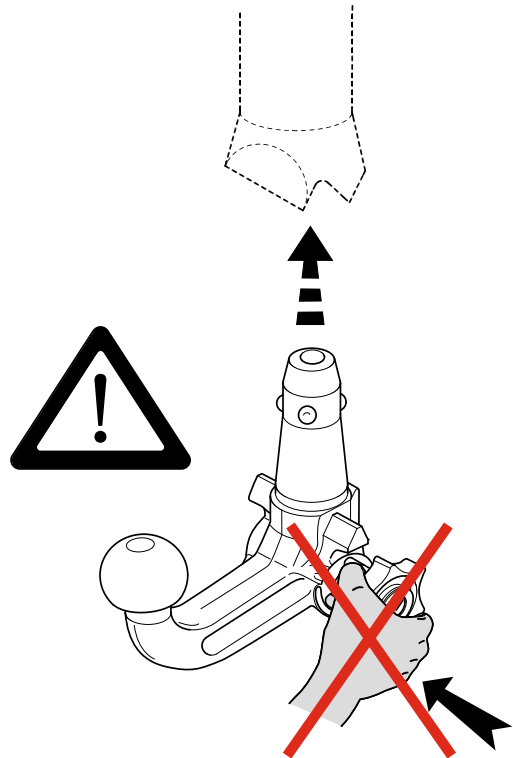
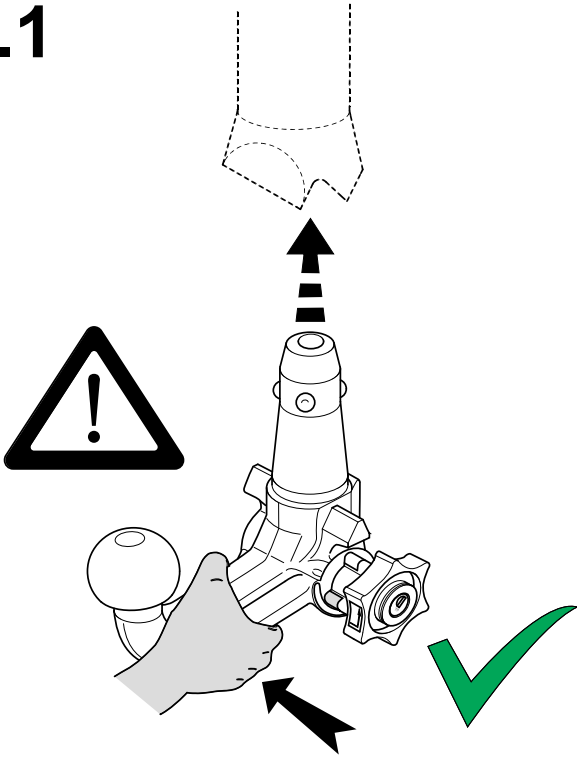

2.2

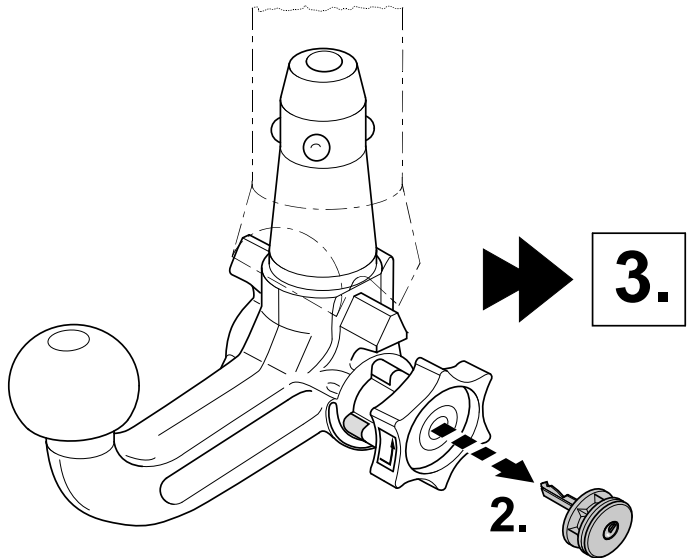
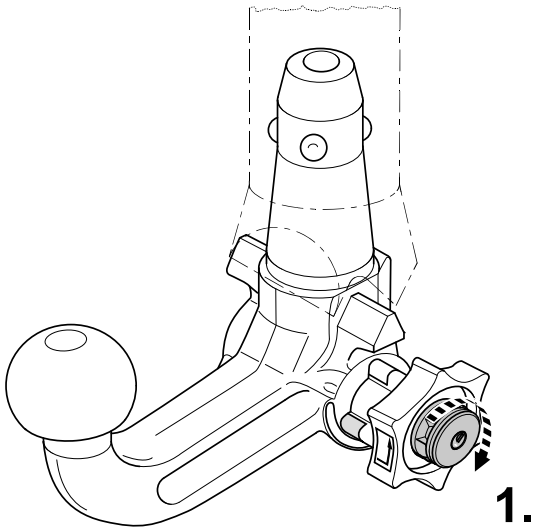



3.

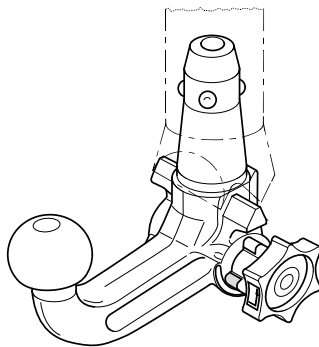

3.1

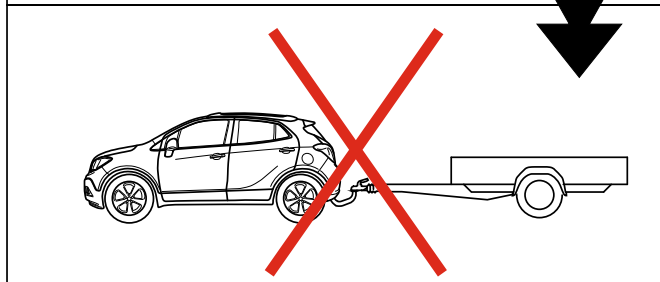
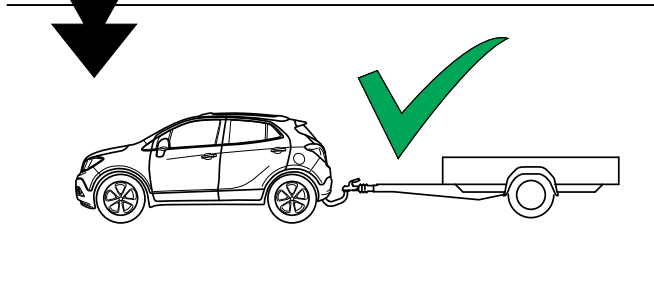
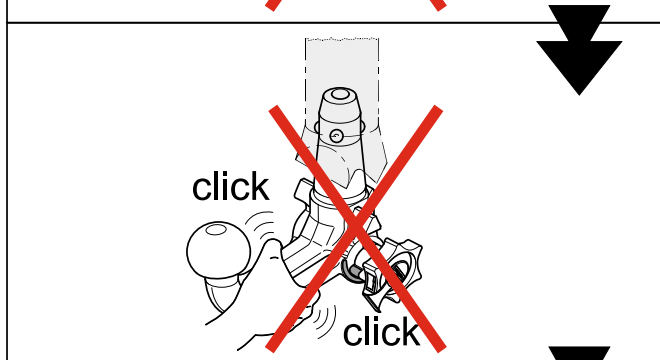
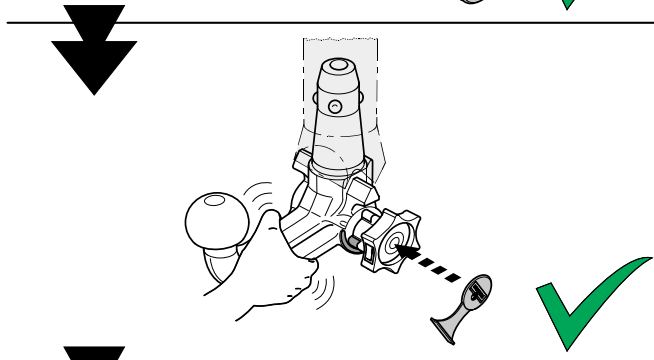
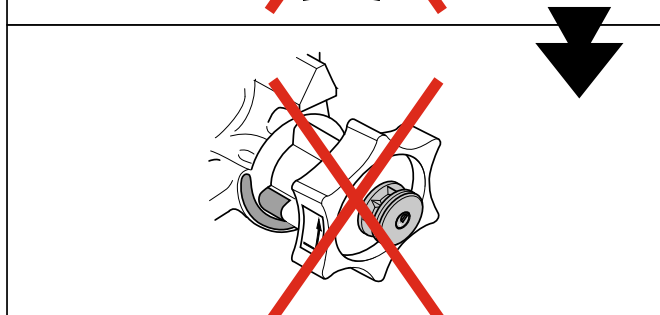
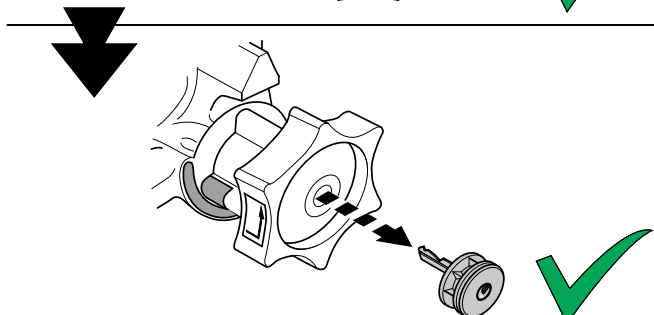
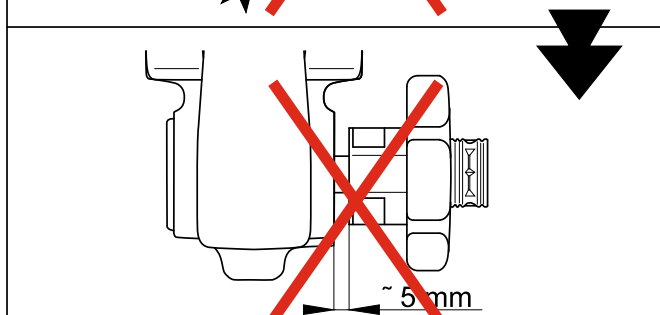
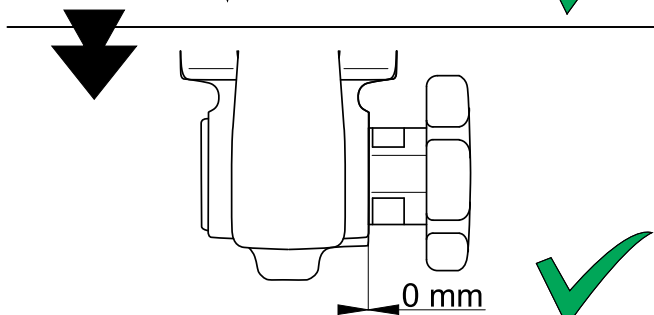
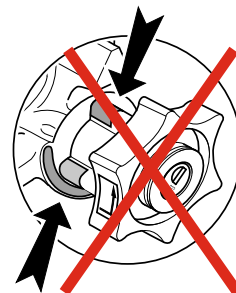
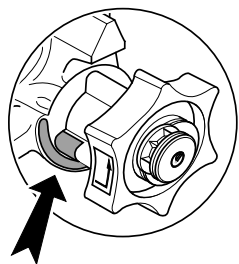

4.

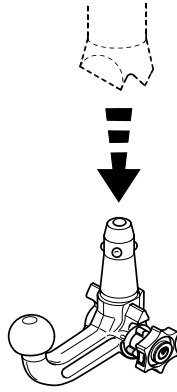

4.1

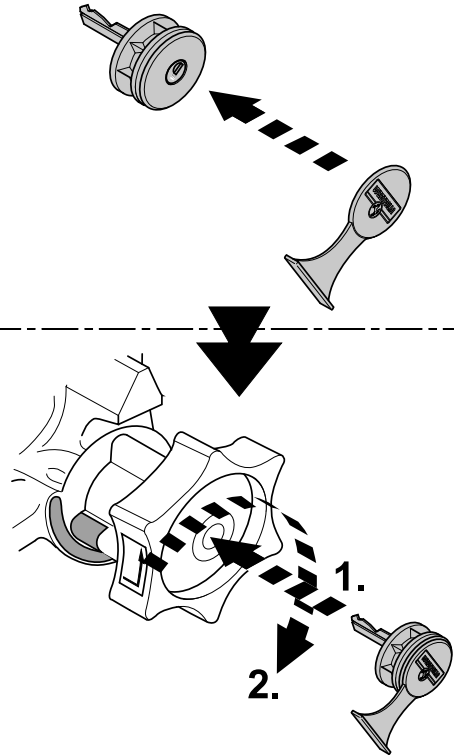
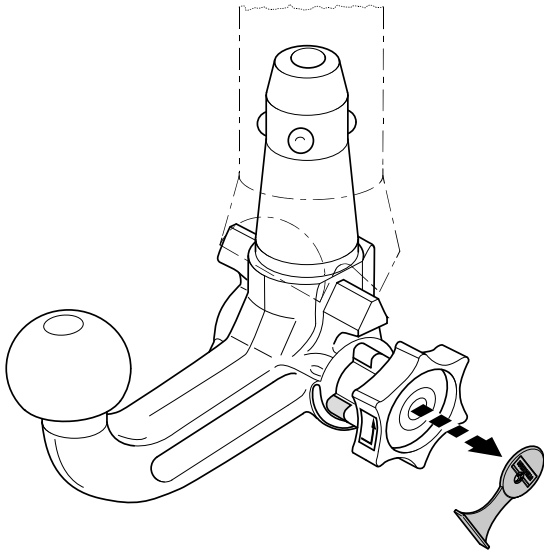

4.2

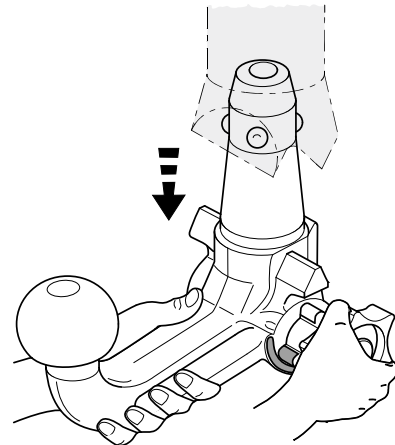
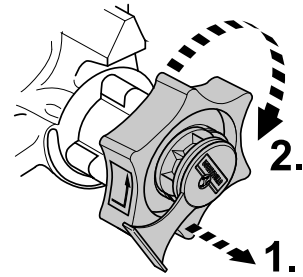
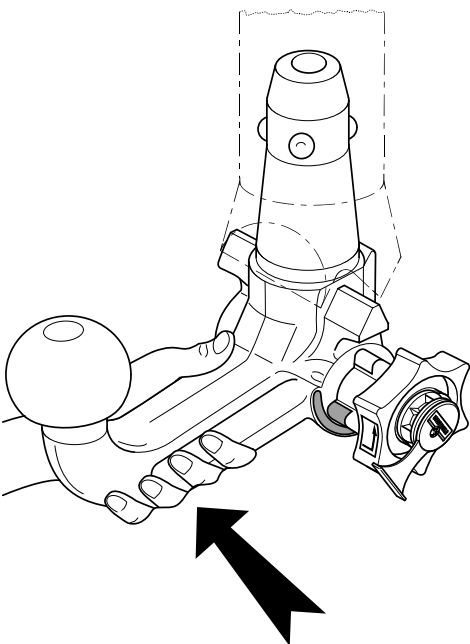

5.

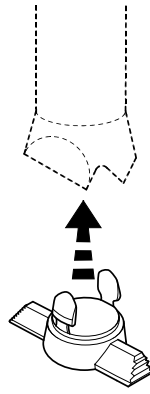

5.1

