

BMW STYLE RUNNING BOARD FOR KIA SORENTO 2015





**ALL NEW
SORENTO**







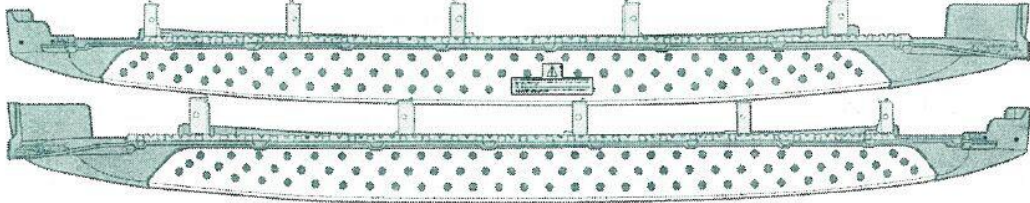
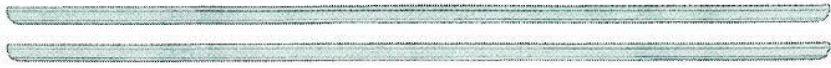



1) Basic Required Hand Tools.

					
Screwdriver 1	Screwdriver 2	Connecting Rod	Piecing	Torque Wrench	Ratchet
					
Screw	Plastic Removal Tool	Vacuum Sweeper	Air Gun	Cutter Knife	Clip Remove Tool
					
Glove	Eye Patch	Car Lifts	Isopropanol	Cleaning Cloth	

2) Accessories

	Running Board
	Running Board Plate
	Hardware Fitting Bag

A		B		C		D		E	
22	Nut	2	Nut	22	M6 Bolt	2	M5 Bolt	1	Washer
F		G		H					
2	Washer	4	Screw	2	Cover Plate				

3) Installing Steps:

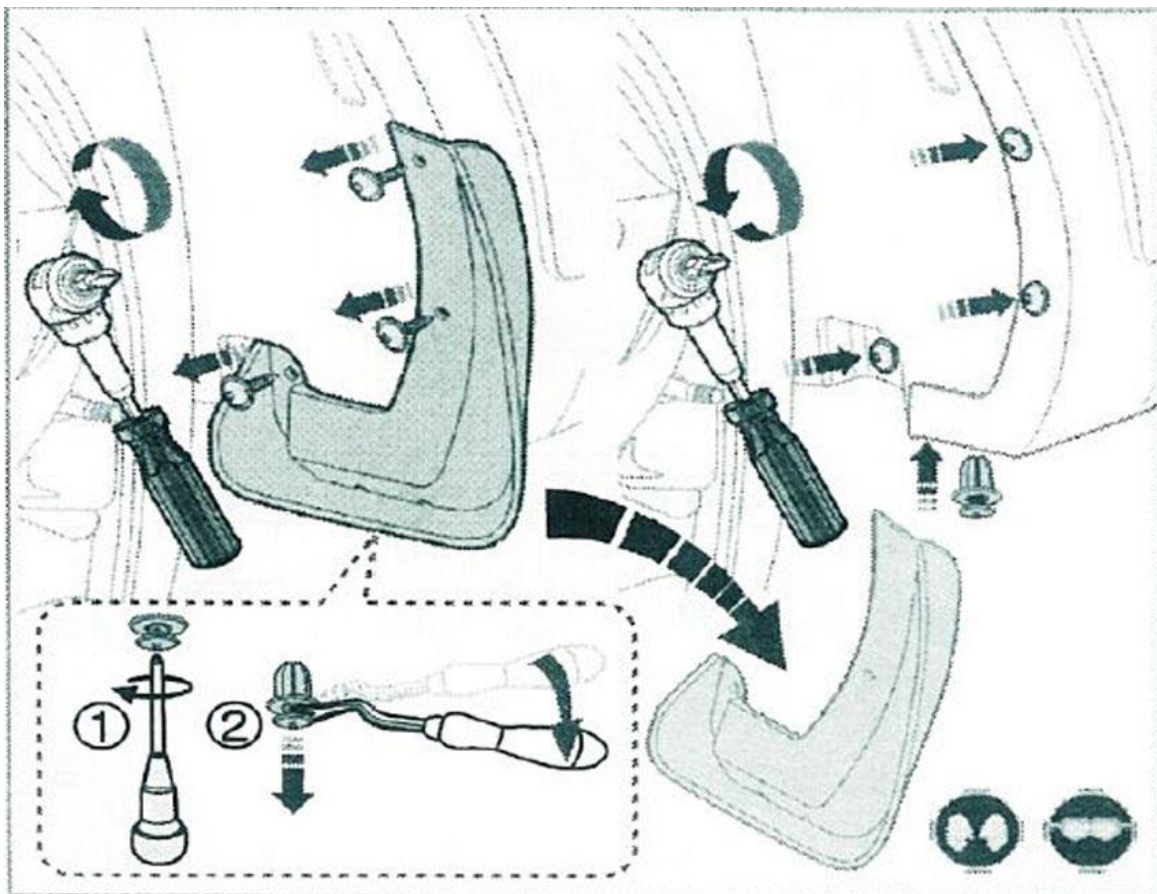

1

N
O
T
E

1. Remove the Plastic under the car and three Screws of front Mud Flap, then keep them for later use
2. Remove the Mud Flap.
3. Re-install the Plastic & three Screws to original position.

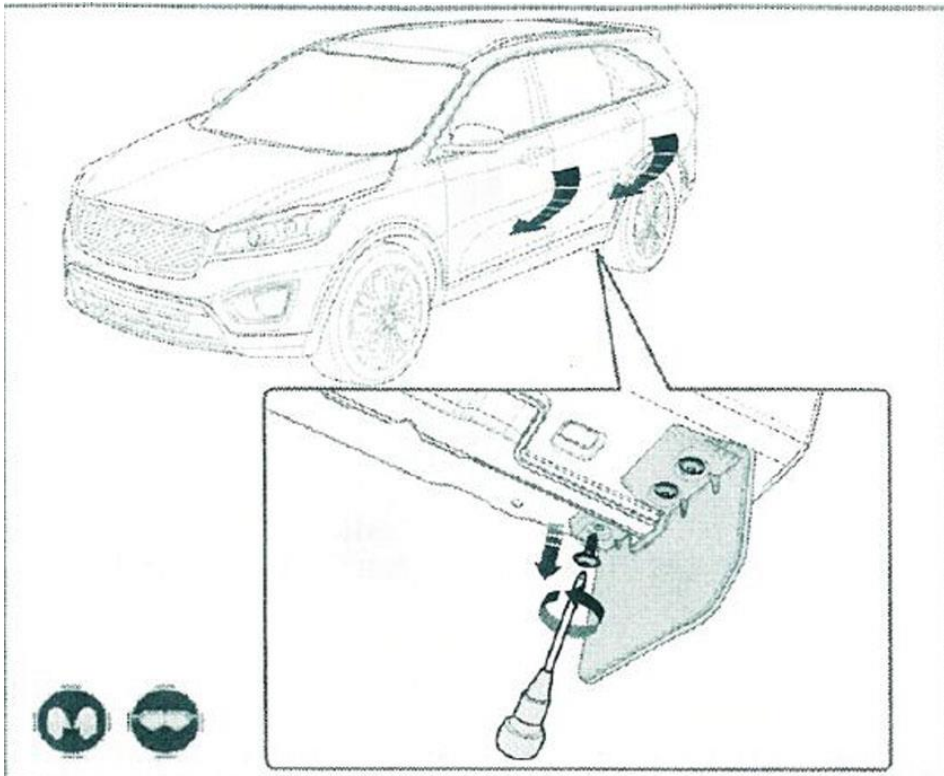

2

**N
O
T
E**

1. Remove rear Mud Flap's three screws and the original skid plate from behind.
2. Open the front & rear side door.

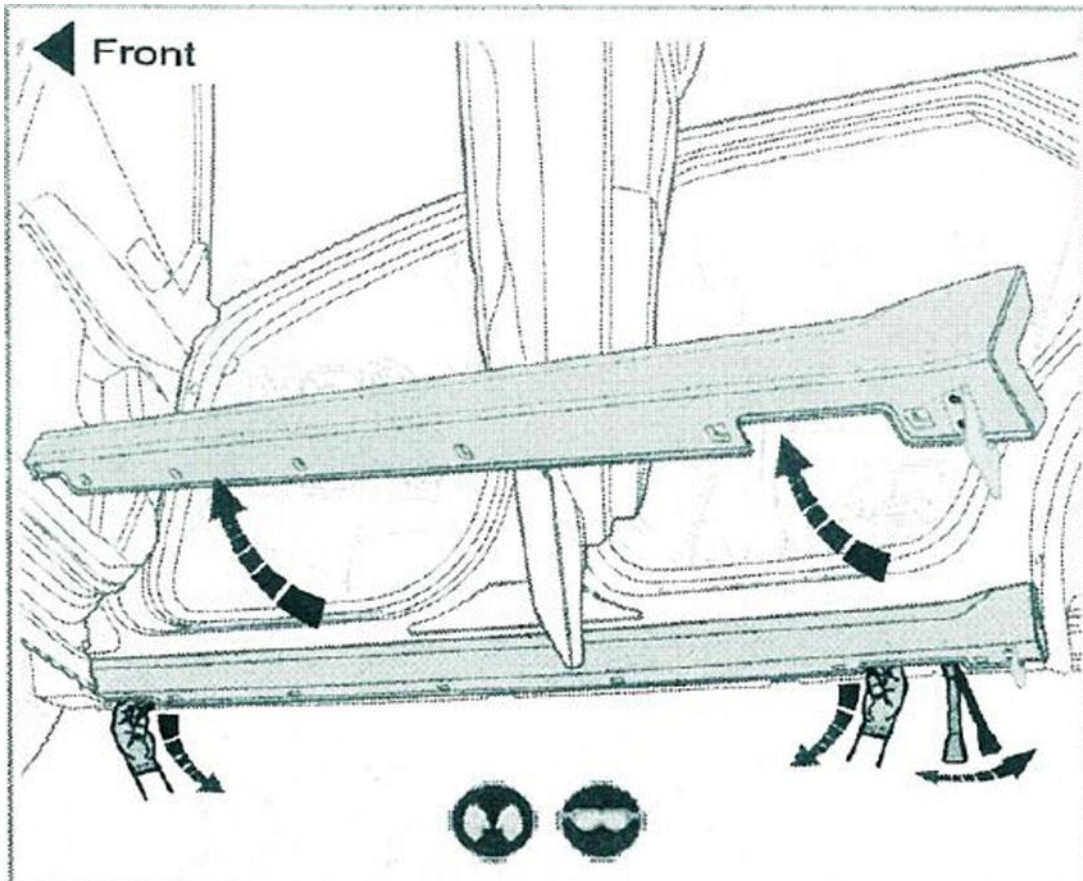

3

NOTE

1. Using hands & Wrench to open a gap during the bottom of side running board and side seal ring.
2. Pull out the side seal ring.

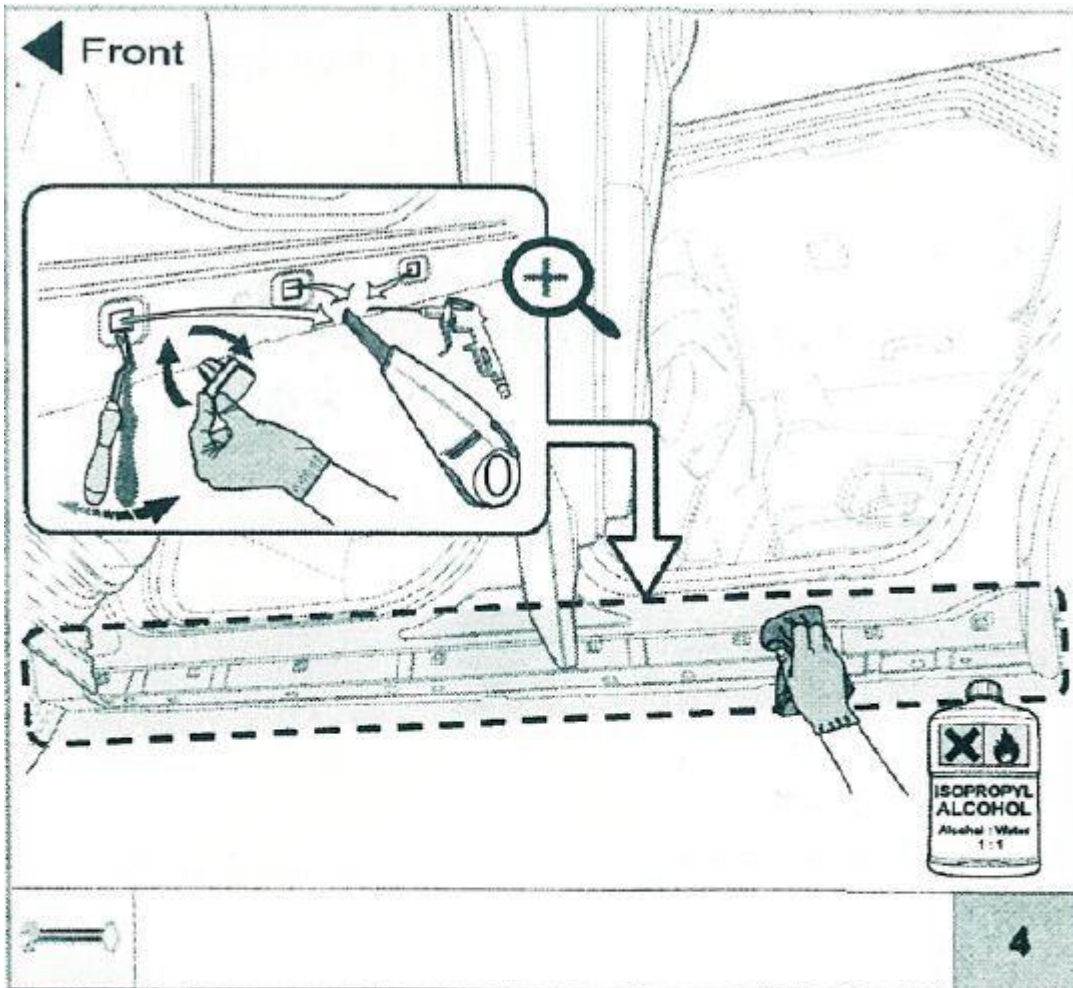

**N
O
T
E**

1. Clean the debris and other things,
Far away from the side edge clip hole
2. Using IPA to clean.

◀ Front

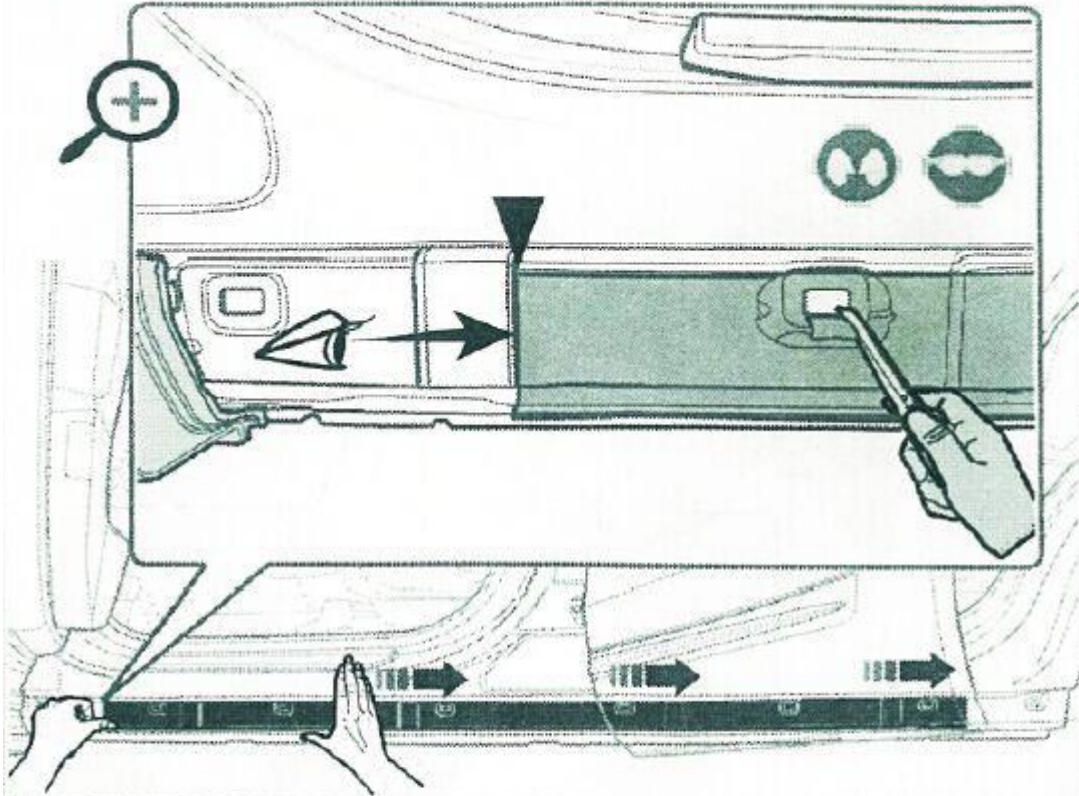

5

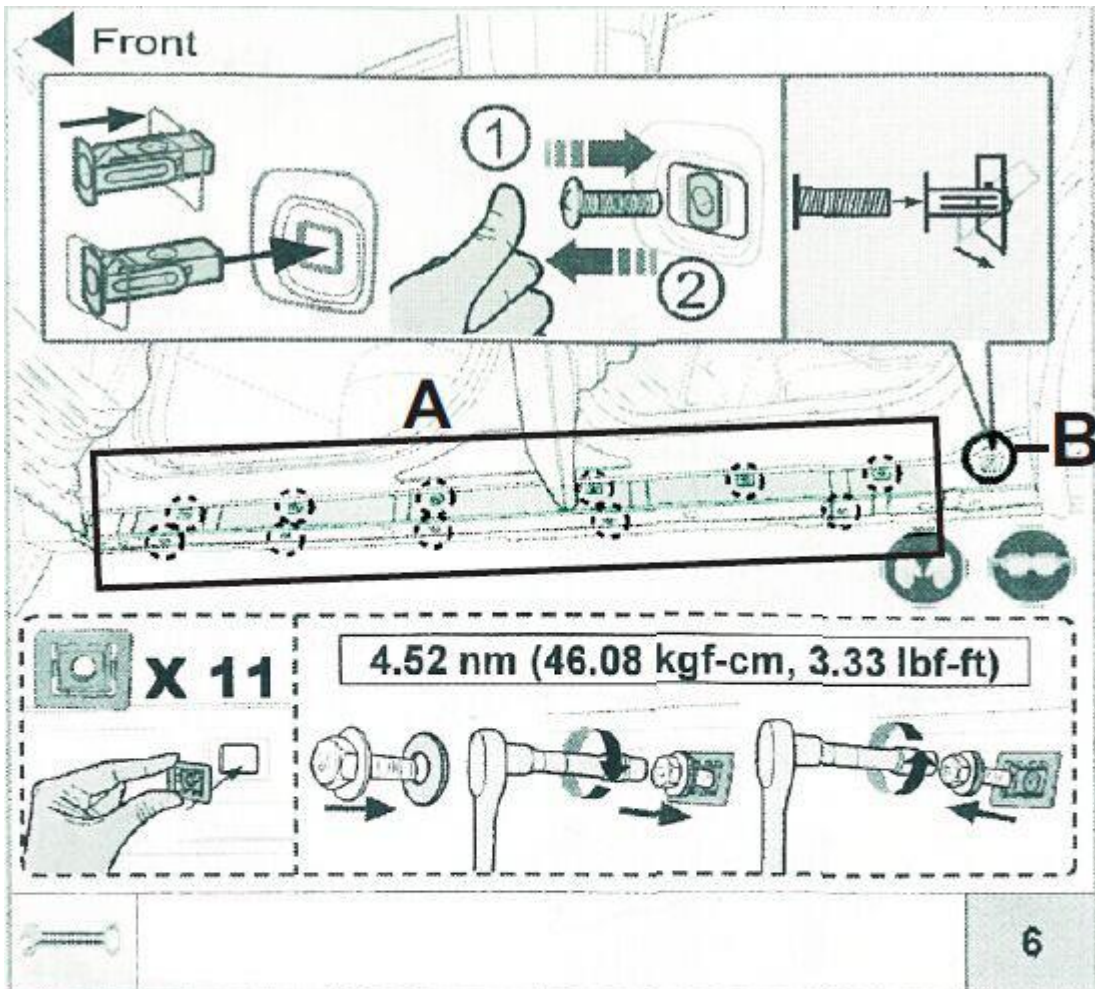

1. Install B Nut into B hole.
2. Install A Nut into A hole (total 11 holes)
3. Install M6 bolt insert A Nut (total 11 pieces)

NOZ

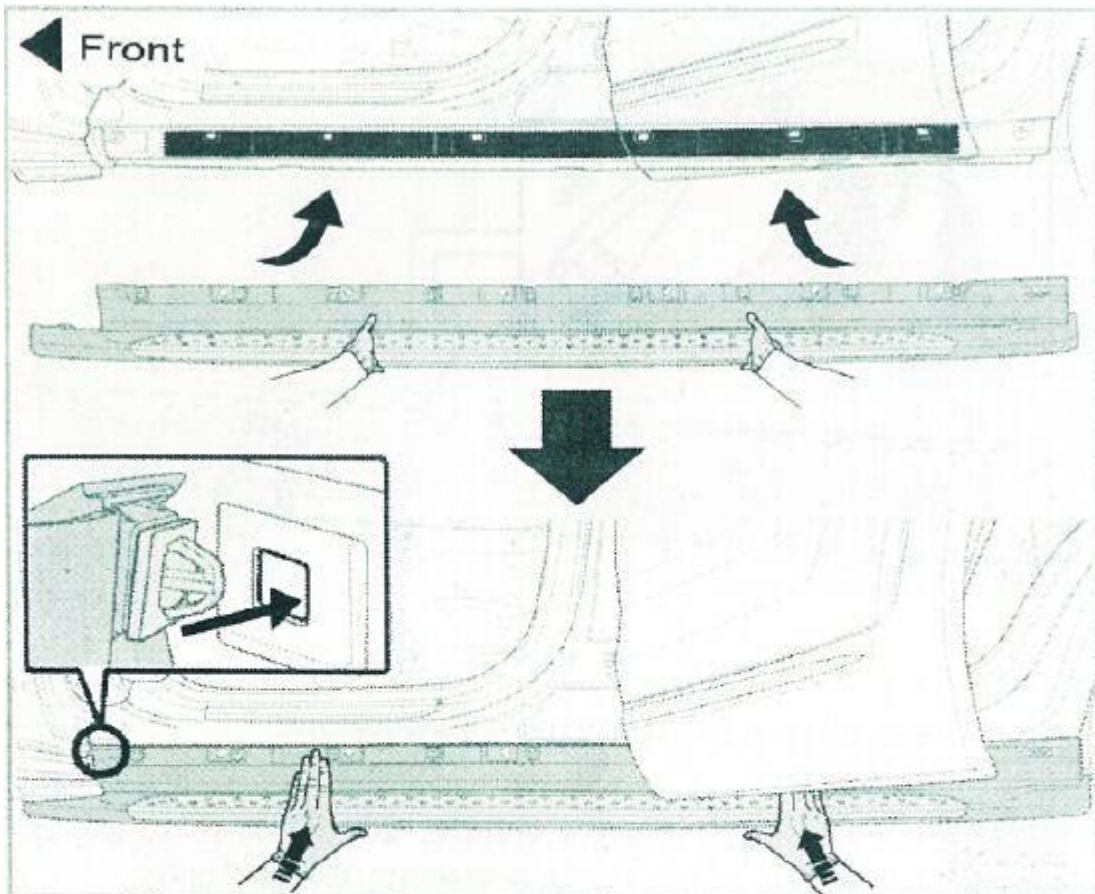

1. Checking the location of the installation running board.
2. Confirm the correct position
(the hole of bottom of running board and the clip hole)

N
O
T
E

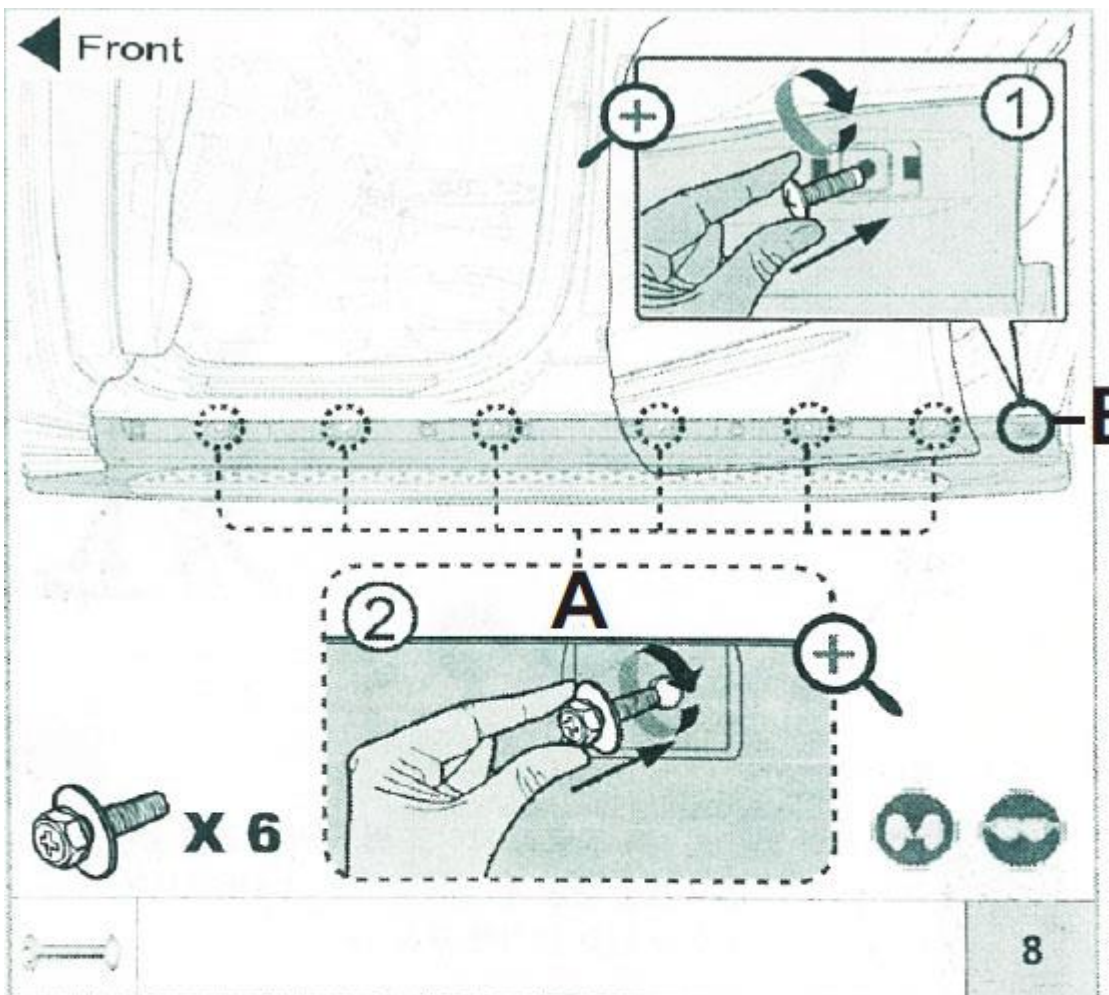

1. Put the M5 bolt into B as showing above, then fixation.
2. Put M6 bolt into A as showing above, then fixation.

N
O
T
E

4.52 nm (46.08 kgf-cm, 3.33 lbf-ft)

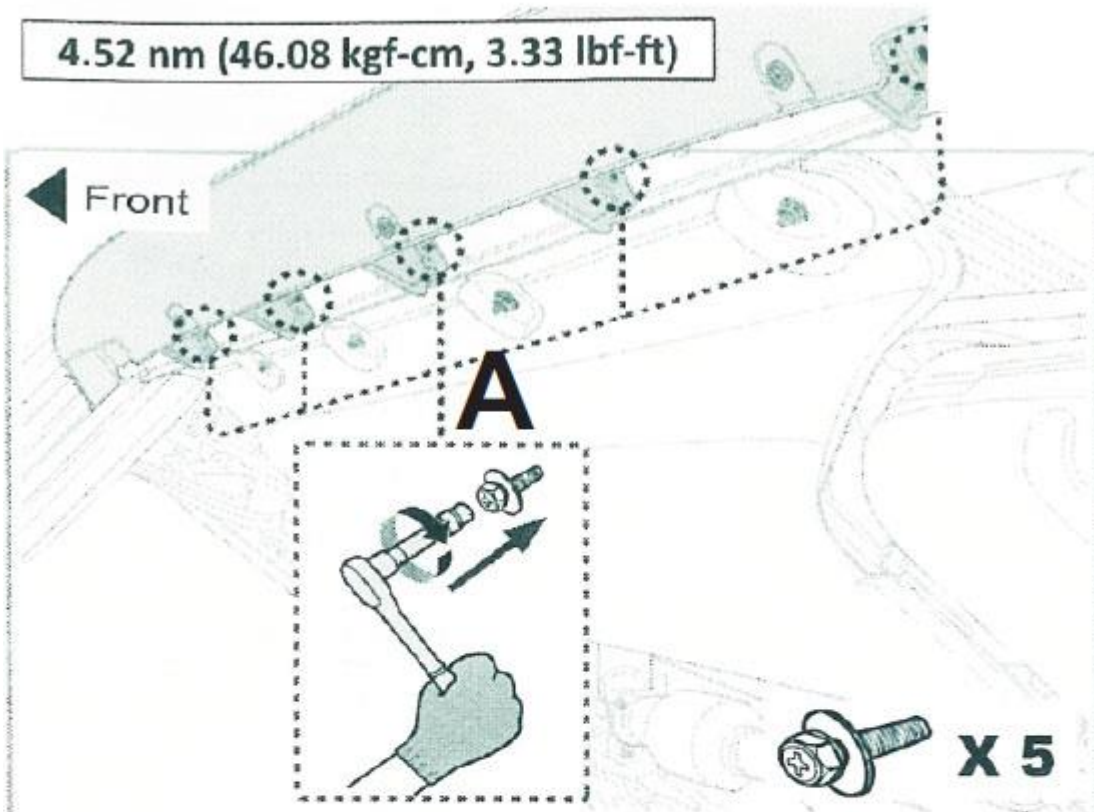

9

Put M6 Bolt into A as showing above, then fixation

N
O

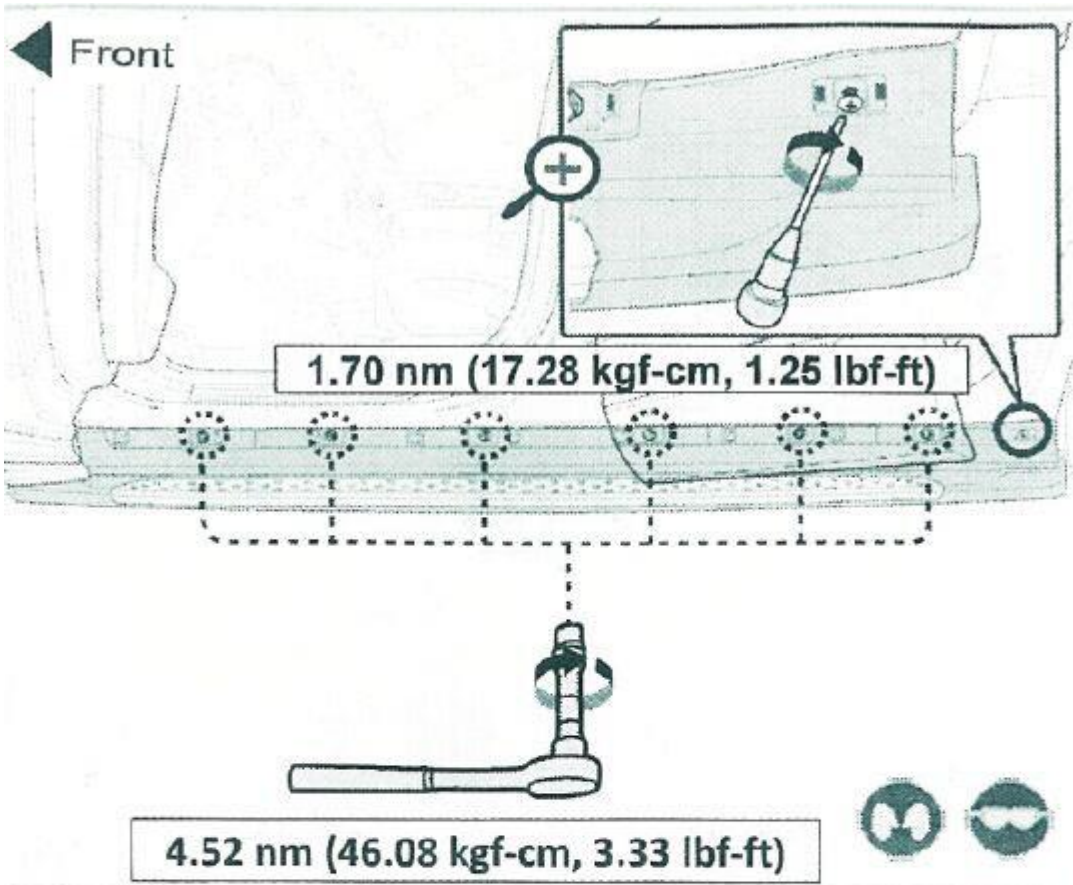

10

NOTE

1. Tighten M5 & M6 Bolt.
2. The torque value of M6 bolt is 46.08kgf-cm.
3. The torque value of M5 bolt is 17.28kgf-cm.

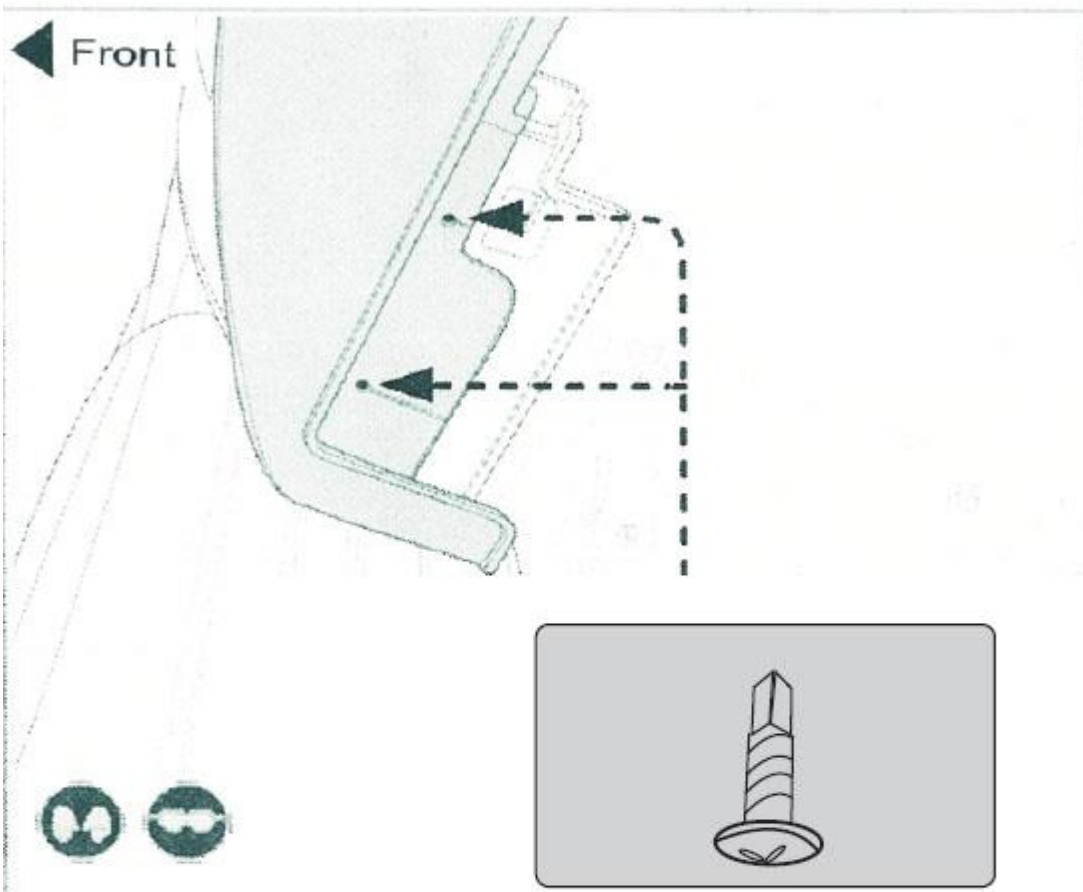

11

**N
O
T
E**

Use Screw to fix as showing above.

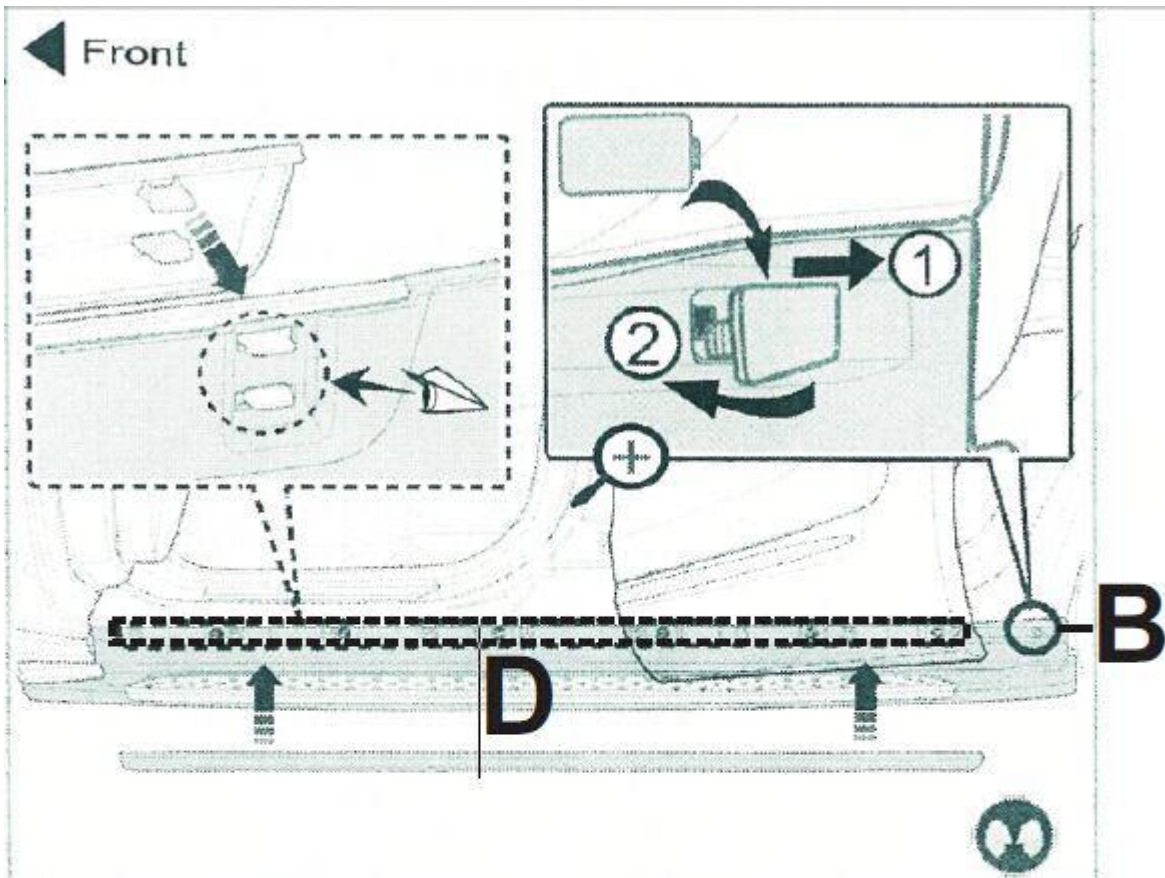

12

N
O
T
E

1. Install the Cover plate into B as showing above.
2. Install the Running Board Plate into D as showing above (align and level them)

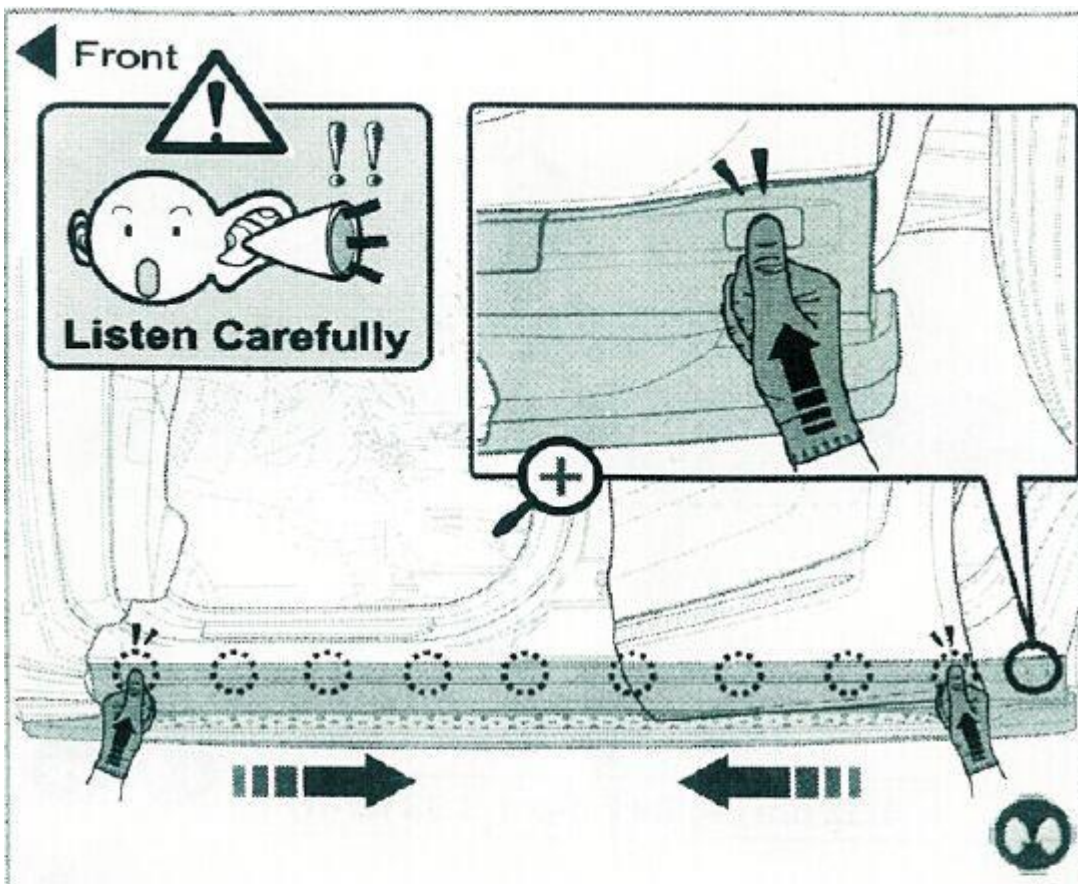

13

N
O
T
E

Please compress all cover plate as showing above

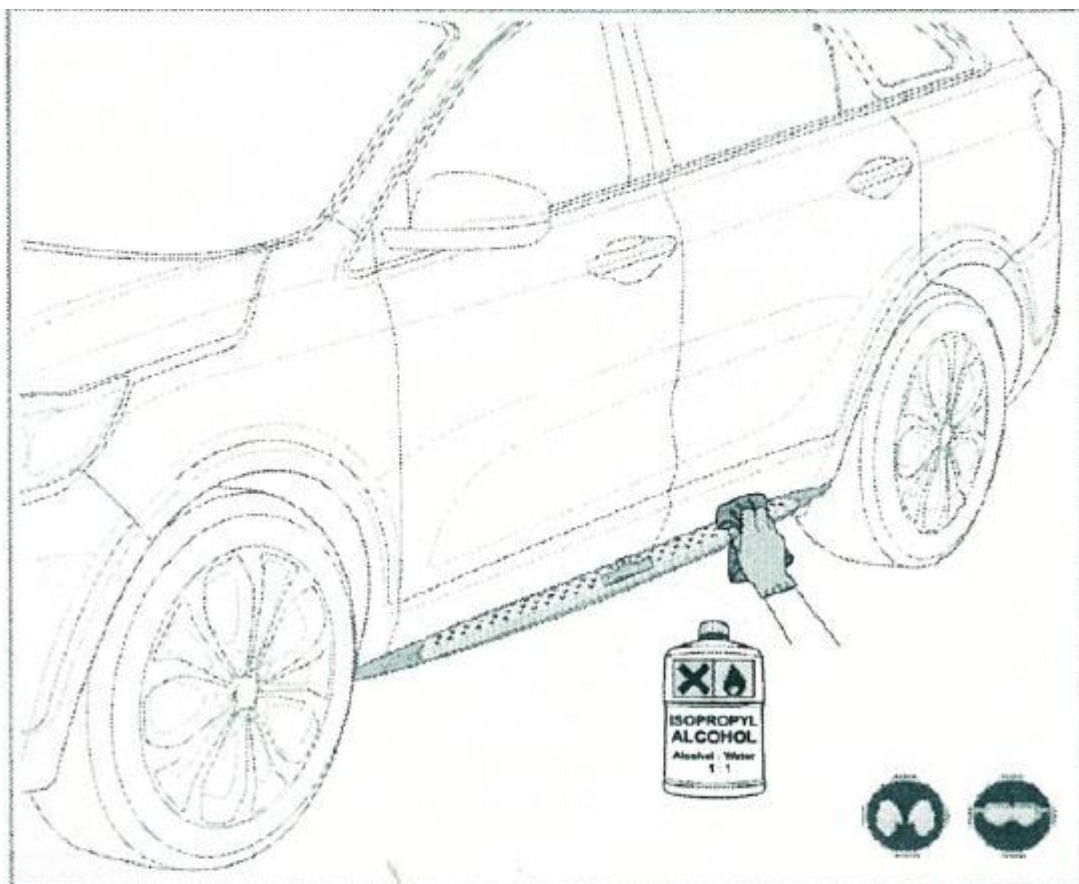

14

N
O
T
E

1. The same way to install the rest running board.
2. Use IPA to clean the running board
3. Finish installation.